

Installing Sail Numbers and National Letters on a 29er Main Sail

By John Papadopoulos
President, US 29er Class Association
March 2, 2016

The 29er Class Rules and the Racing Rules of Sailing contain the specifications to follow in placing the National Letters (aka Country Code) and Sail Numbers on your 29er Mainsail. The applicable portions of the current rules are as follows:

See 29er Class Rules ([Click this link...29er2016CR010116-\[19816\].pdf](#))

C.10.3 MAINSAIL

(a) IDENTIFICATION

- (i) The national letters and the sail numbers shall be black and shall comply with the RRS G.1.2 except where specified in C.10.3 (ii).
- (ii) National letters shall be placed in front of or above the sail numbers for which both shall comply with the specifications in the RRS Appendix G1.2 for boats under 3.5 metres.
- (iii) The national letters and the sail numbers shall be wholly between the 2nd and 4th batten pockets from the head point.
- (iv) The base of the national letters and the sail numbers shall be approximately parallel to the batten pockets
- (v) The sail number shall be either:
 - (1) If either of the crew has finished in the top 25 in the preceding 29er world championship their sail number may be that place, 1st to 9th single digit, otherwise two digits.
 - (2) Otherwise, the sail number shall be that shown on the World Sailing hull plaque.
 - (3) Should there be multiplicity in numbers due to C.10.3(a)(v)(1), a race committee may make an arrangement suitable for the duration of the event involved.

Racing Rules of Sailing G1.2

- (a) National letters and sail numbers shall be in capital letters and Arabic numerals, clearly legible and of the same colour. Commercially available typefaces giving the same or better legibility than Helvetica are acceptable.
- (b) The height of characters and space between adjoining characters on the same and opposite sides of the sail shall be related to the boat's overall length as follows:

<i>Overall length</i>	<i>Minimum height</i>	<i>Minimum space between characters and from edge of sail</i>
Under 3.5 m	230 mm	45 mm
3.5 m – 8.5 m	300 mm	60 mm
8.5 m – 11 m	375 mm	75 mm
Over 11 m	450 mm	90 mm

Placement Options

There are two styles of placing the National Letters and the Sail Numbers: you can place the National Letters either in front of the sail number or above the sail number.

The first, or old, version is to place the National Letters and sail Numbers in one row. Historically the characters were placed between the 2nd and 3rd batten pockets, as is illustrated below however they can now be placed below the 3rd batten pocket (not illustrated) if desired.

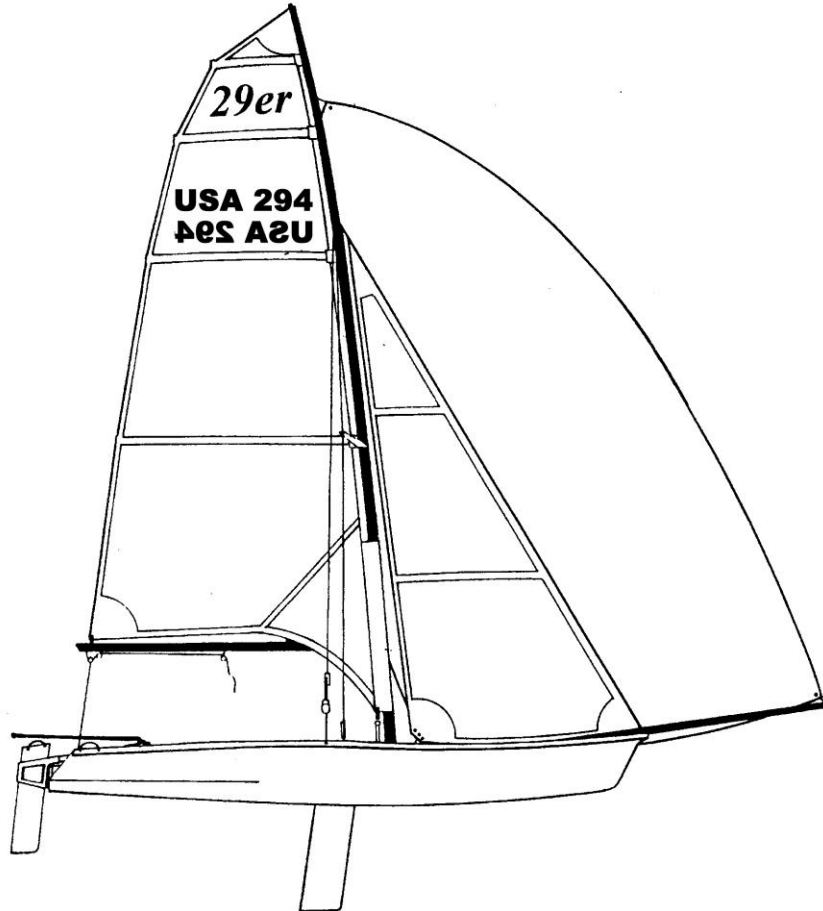

The second style came about because the sail numbers were requiring more space than was available between the 2nd and 3rd battens. Two changes were made to the rules: 1) allow national letters above the sail numbers and 2) allow use of the space between the 3rd and 4th battens. It is now customary to put the characters as is illustrated and photographed below:

The second style is recommended over the first style as the sail numbers and national letters are easier to read from a distance – which means the race committee will make fewer mistakes recording finishes.

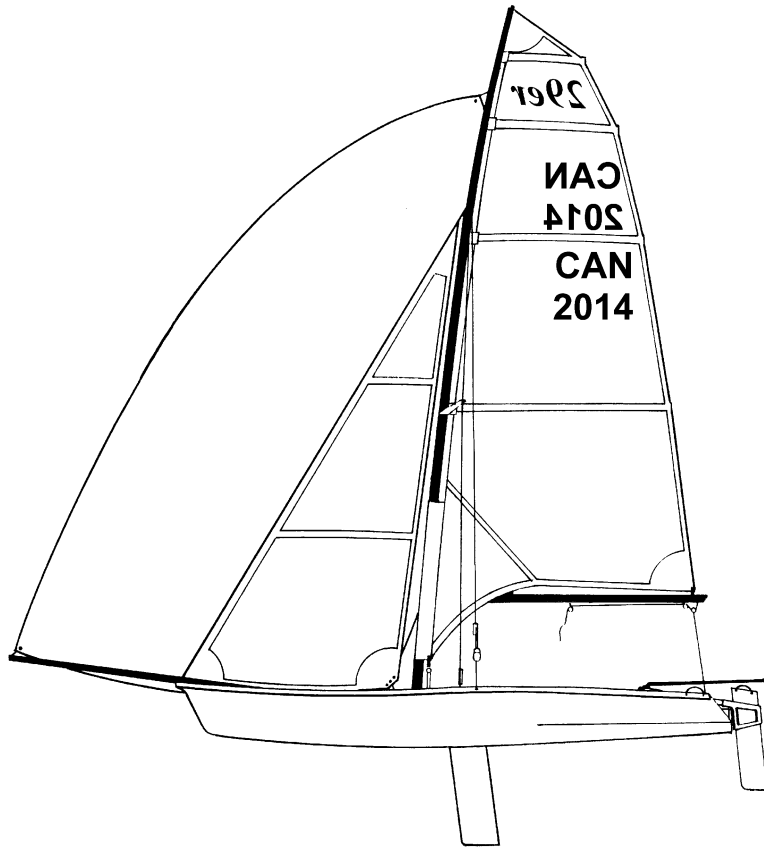

Rules Summary:

- Black characters
- Minimum height of letters and numbers: 230mm (round to 10" using English unit system)
- Minimum space between characters: 45mm (round to 2" using English unit system)
- Minimum space between the edge of the sail and characters: 45mm (round to 2" using English unit system)
- Upper National Letters and Sail Numbers are on the starboard side of the sail.

Tips for Installation:

- 1) Place the sail on a flat and clean surface so the port side is facing up (starboard side is down).
- 2) Using a straight edge to guide you, place low-stick masking tape above and parallel to the 3rd batten pocket so that the "upper" edge of the tape is at least 50mm (approximately 2") from the pocket.
- 3) Place masking tape along the leach so that the "inner" edge is at least 50mm (or 2") in from the edge of the sail
- 4) Place the last digit of your Sail Number so that its bottom and "aft" edges are aligned and next to the masking tape. Professional tip: estimate the position of the National Letters first and place the sail number so that the aft edge of the last digit lines up with the aft edge of the last.
- 5) Place the remaining sail numbers with 50mm (or 2") between each digit.
- 6) Place National Letters so there is at least 50mm (or 2") of space between the numbers and letters
- 7) Flip sail over and repeat the above steps, adjusting for the fact that you'll be putting the National Letters on first.