



TRED AVON YACHT CLUB
2016
HERITAGE REGATTA - LOG CANOE COURSE
Sailing Instructions
 Amended August 22, 2016

**1 RULES**

The regatta will be governed by *The Racing Rules of Sailing*, the prescriptions of US Sailing, as modified by CBYRA, the rules of the Chesapeake Bay Log Sailing Canoe Association (CBLSCA), except as any of these are changed by the sailing instructions or by the PRO at the Skipper's Meeting.

2 ENTRIES

Eligible boats may be entered by completing registration with the Tred Avon Yacht Club by 0900 on the day of the first race. Only boats owned by members of the CBLSCA and with current measurement certificates are eligible. A Skipper's Meeting is scheduled at 0900 on Saturday on the Lower porch at TAYC Clubhouse. There is no entry fee.

3 NOTICES TO COMPETITORS

Notices to competitors will be posted on the official notice board located in the clubhouse lobby.

4 CHANGES IN SAILING INSTRUCTIONS

Any change to the sailing instructions will be posted before 0900 on the day it will take effect, except that any change to the schedule of races will be posted by 2000 on the day before it will take effect. Changes made at the Skipper's Meeting will be posted in writing immediately following the meeting on the official notice board located in the clubhouse lobby.

5 SCHEDULE OF RACES

<u>Race</u>	<u>Date</u>	<u>Warning Signal</u>
1	Sat. Aug 27	1030
2	Sat. Aug 27	1430
3	Sun. Aug 28	1030

6 RACING AREA

The racing area for log canoes is approximately between Tred Avon Yacht Club and Choptank River Light. Committee boat will fly the Race Committee flag.

7 THE COURSE

The course will be displayed at the Race Committee Signal boat prior to the Warning Signal. The letters will be displayed on the starboard side of the signal boat.

7.1 If the selected course is windward-leeward or triangle, the course will be designated by a letter corresponding to the course diagram examples. The course letter will be followed by a numeral indicating the number of windward legs to be sailed (that number may be different than diagram example). Red letters indicate marks to be left to port, green or black letters indicate marks are to be left to starboard.

7.2 If the selected course is comprised of random marks, the course will be designated by letters displayed in the sequence the marks are to be passed. Red letters indicate marks to be left to port, green or black letters indicate marks are to be left to starboard. A numeral following the sequence indicates the number of times the course is to be sailed.

7.3 Blank

7.4 **A boat shall not pass through the start/finish line of any other fleet. A boat infringing this rule cannot exonerate herself and will be disqualified.**

8 MARKS

Orange Club marks are 6' tall inflatable cylinders, a 4' "pin" may be substituted to establish an end of the starting or finishing line.

- A Club start / finish mark
- B Club mark near Benoni Pt Light "1"
- C Club mark near Bachelors Pt
- F Club mark near Fox Hole Creek
- N Government Mark "2" off TAYC
- L Choptank River Lighthouse
- P Government Mark "4" Peck's Point

- S Club mark near Pier Street
 X Club mark near Tar & Plaindealing Crk

9 THE START

- 9.1 Signals shall be made at five-minute intervals (10 minute sequence). Times shall be taken from the visual signals; the failure of a sound signal shall be disregarded. Signals shall be as follows:

Warning signal - yellow shape & sound
 Preparatory signal - blue shape & sound
 Starting signal - red shape & sound
 Each signal shall be removed one minute before the next is made. This changes RRS 26.

- 9.2 The starting line will be between an orange flag on the race committee boat and an orange cylinder marking the other end.
- 9.3 The signal boat may at its discretion attach a buoy or marker to itself; such an attachment shall be considered part of the signal boat.
- 9.4 A boat shall not start later than 10 minutes after her starting signal.
- 9.5 The decision to start a race shall be made by each skipper and is his/her sole responsibility. Competitors participate in the regatta entirely at their own risk.

10 MARK BOATS

A mark boat will attempt to be in the proximity of the next mark to be rounded. Failure of the mark boat to be on station or to display a flag will not be grounds for redress.

11 CHANGE OF COURSE AFTER THE START

A change of course after the start will be signaled before the leading boat has begun the leg, although the new mark may not then be in position. Any mark to be rounded after the new mark may be relocated to maintain the original course configuration.

12 THE FINISH

The finishing line will be between an orange flag on a race committee boat and the nearby mark.

13 PENALTY SYSTEM

RRS 44 is changed to "one turn" wherever the phrase "two turns" occurs.

14 TIME LIMIT

The first boat must cross the finish line within the following time limits: 2 ½ hours, if two races are scheduled for the day, 3 hours if one race is scheduled. Any boat that finishes 45 minutes after the first boat has finished shall be scored as DNF.

15 PROTESTS

- 15.1 Protests shall be written on U.S. Sailing protest forms available at the Club office or the race notice board. They are to be delivered to a member of the Log Canoe Race Committee or the Protest Committee within 1 hr after the committee boat ties to the dock after the last race of the day. Docking time will be posted.
- 15.2 Protests will be heard as soon as possible. Hearing time and location will be broadcast on the P.A. system and posted on the official notice board.

16 SCORING

The Low Point System, Appendix A, will apply. 3 races are scheduled, of which 1 race shall be completed to constitute a series. No race score shall be discarded.

17 SAFETY

All canoes shall have a chase boat/tender with life jackets for all crew. All canoes must have a life ring or throwable cushion with a rope. Any crewmember who cannot swim must wear a life jacket. It is the sole responsibility of the owner and/or skipper to ensure that these requirements are met.

18 PRIZES

Awards will be presented at a reception at TAYC Clubhouse as soon as possible after racing has concluded.

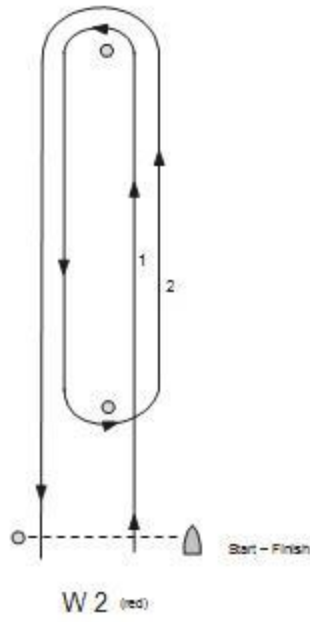
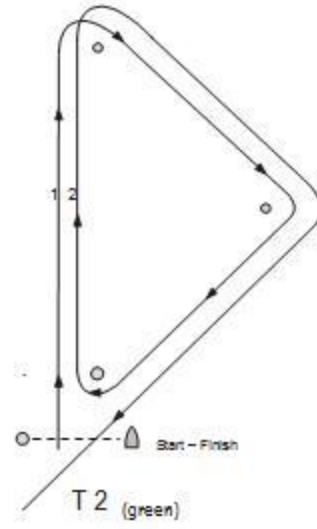
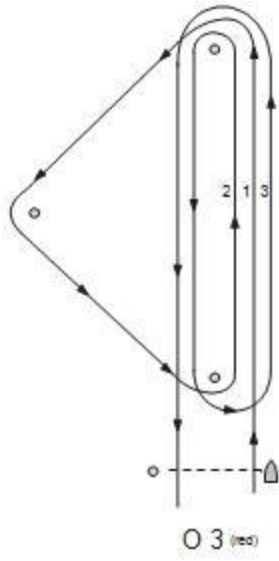

LOG CANOE RACE SHEET

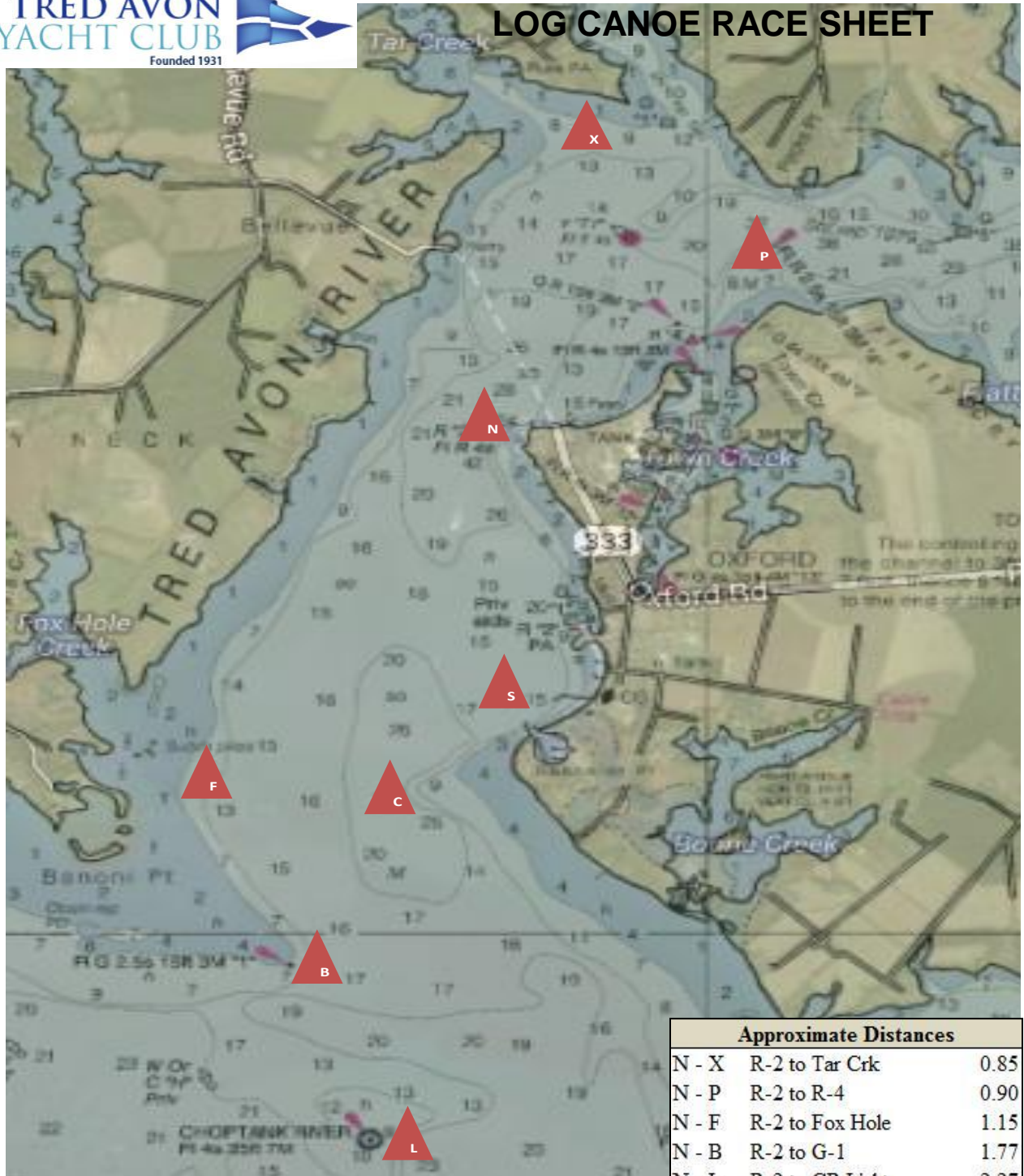

MARKS

Orange Club marks are 6' tall inflatable cylinders, a 4' "pin" may be substituted to establish an end of the starting or finishing line.

- A Club start / finish mark
- B Club mark near Benoni Pt Light "1"
- C Club mark near Bachelors Pt
- F Club mark near Fox Hole Creek
- N Government Mark "2" off TAYC
- L Choptank River Lighthouse
- P Government Mark "4" Peck's Point
- S Club mark near Pier Street
- X Club mark near Tar & Plaindealing Crk

Approximate Distances

N - X	R-2 to Tar Crk	0.85
N - P	R-2 to R-4	0.90
N - F	R-2 to Fox Hole	1.15
N - B	R-2 to G-1	1.77
N - L	R-2 to CR Light	2.27
N - C	R-2 to Bach Pt	
N - S	R-2 to Pier St	0.80
F - B	Fox Hole to G-1	
F - L	Fox Hole to CR Light	
F - S	Fox Hole to Pier St	0.70
F - B	Fox Hole to Tar Crk	
F - C	Fox Hole to Bach Pt	
X - P	Tar Crk to R-4	
B - L	G-1 to CR Light	0.58
B - C	G-1 to Bach Pt	
B - X	G-1 to Tar Crk	
C - S	Bach Pt to Pier St	