



SAILING INSTRUCTIONS

AREA D Qualifier

for

The US Sailing Chubb U.S. Junior Championships

The U.S. Junior Triplehanded Sailing Championship for the Sears Cup

Mobile Yacht Club, July 22-23, 2016

posted June 22, 2016

1 RULES

- 1.1 The regatta will be governed by the rules as defined in The Racing Rules of Sailing.
- 1.2 The following documents will apply:
 - a) US Sailing Regulations
 - b) The Conditions for the United States Junior Sailing Championships and the US Sailing Championship Conditions <http://championships.ussailing.org/Youth/ChubbJrChampionships/Conditions.htm>
www.ussailing.org/racing/championships
 - c) The US Sailing Championship Support Vessel Policy. <http://www.ussailing.org/racing/championships/coaching-and-support-boats-policy>
- 1.3 In case of conflict between the Notice of Race and the Sailing Instructions, the Sailing Instructions will prevail. This changes rule 63.7.

2 NOTICES TO COMPETITORS

Notices to Competitors will be posted on the official regatta notice board located under Mobile Yacht Club.

3 CHANGES TO SAILING INSTRUCTIONS

Changes to the SIs will be posted no later than 20 minutes after the close of the morning briefing on the day it takes effect. Except any change to the schedule of races will be posted no later than the end of the protest time limit on the day before it will take effect.

4 SIGNALS MADE ASHORE

- 4.1 Signals ashore will be displayed from the main yardarm.
- 4.2 Boats are not allowed to launch before code flag D is displayed with one sound. (optional)
- 4.3 When flag AP is displayed ashore, '1 minute' is replaced with 'not less than 60 minutes' in the race signal AP. Boats shall not leave the harbor; wait for further instructions. This changes rule Race Signals AP.

5 SAFETY AND PERSONAL EQUIPMENT

- 5.1 All competitors in US Sailing Championships, at all levels, shall wear, while on the water, other than brief periods while adding or removing clothing, an approved US Coast Guard PFD that depends 100% on foam for flotation that is the appropriate size for the sailor. The PFD must be worn outside of all clothing, except that a thin shirt may be worn over the PFD to prevent snagging.
- 5.2 Before the warning signal of the first race in which they intend to compete each day, boats shall check in by sailing on starboard tack of their class's race committee signal boat. Each boat shall hail her sail number until acknowledged by the signal boat. Failure to check in may result in a penalty.
- 5.3 A boat retiring from a race shall notify a RC vessel before leaving the course, or, when that is impossible, at immediately after arrival ashore.
- 5.4 The only gear, rigging, or equipment that a team may take aboard a boat shall be: magnetic card compass, flags, plastic bucket or bailer, normally equipped ditty-bag, personal effects, including PFDs and protective clothing.
- 5.5 Electronic fluxgate compasses and GPS devices of all varieties, styles and combinations are specifically banned.

6 SCHEDULE OF RACES

6.1

| | | |
|-------------------------|---|---|
| Friday, July 22, 2016 | 1000 – 1100 | Check-in |
| Friday, July 22, 2016 | 1100 immediately following 1255 Subsequent races to follow | Mandatory competitors meeting Mandatory Coaches meeting Warning of first race |
| Saturday, July 23, 2016 | Reserved for completing series if necessary | |

6.2 There are a maximum of 5 races scheduled.

6.3 The warning signal for succeeding races will be made as soon as possible after finish of preceding race.

6.4 To alert boats that a race will begin soon, an orange flag will be displayed with one sound for at least 4 minutes before a warning signal is displayed.

6.5 Weather conditions, the need to protect borrowed boats and equipment, or the need to expedite the completion of the event may require procedures other than those mentioned in these Sailing Instructions. Any such special procedures must be approved by the Protest Committee.

6.6 **Shortened Event.** Should wind, weather or other conditions make it impossible to complete the scheduled number of races within the publicized time, the event shall be terminated and the results based on the completed number of races. Termination and decisions regarding results shall be made by the Protest Committee.

7 CLASS FLAG

The class flag will be MYC burgee

8 RACING AREA

The sailing area will be on Mobile Bay, east of Mobile Yacht Club.

9 THE COURSE

9.1 The diagrams in Attachment C show the courses, including the course signals, the order in which marks are to be passed, and the side on each mark is to be left.

9.2 No later than the warning signal, the race committee signal boat shall display the course designation and the approximate compass bearing of the first leg.

10 MARKS

10.1 Rounding marks will be orange tetrahedrons.

10.2 New marks will be yellow tetrahedrons.

10.3 If a buoy is used as a mark at the finish line it will be an orange sphere.

11 THE START

11.1 The starting line will be between a staff displaying an orange flag on the race committee signal boat and the course side of the mark or a staff displaying an orange flag on a race committee boat at the port end of the line.

11.2 A boat starting later than 4 minutes after her starting signal will be scored DNS. This changes rules 63.1 and A5.

12 RECALLS

12.1 The RC will attempt to hail the sail numbers of OCS boats after the starting signal. This changes rule 29.1.

12.2 The failure of any boat to hear the hail, promptness of the hail, failure to hail any boats, or the order of boats hailed shall not be grounds for redress. This changes rule 62.1.

13 CHANGE THE NEXT LEG OF THE COURSE

- 13.1 To change the next leg of the course, the committee will lay a new mark (or move the finishing line) and remove the old marks as soon as practicable.

14 THE FINISH

- 14.1 The finishing line will be between a staff displaying an orange flag on a RC boat and the course side of the designated finish mark.

15 TIME LIMIT

- 15.1 The time limit for each race will be 90 minutes for the first boat to finish.
- 15.2 Boats failing to finish within 15 minutes after the first boat that sails the course in accordance with rule 28 finishes will be scored TLE (Time Limit Expired) without a hearing. These boats that did not finish within this finishing window will be assigned points equal to two plus the number of finishers in that race that did finish within the finishing window in accordance with rule 28. This changes rules 35, 63.1, A4 and A5.

16 EVENT PROTESTS AND REQUESTS FOR REDRESS

- 16.1 A boat is not permitted to protest another boat for breaking sailing instructions 2, 5.2, 5.3, 6.2, 6.3, 21, or 22. The penalty for breaking these instructions may be less than disqualification at the discretion of the protest committee. This changes rule 60.1(a).
- 16.2 A boat intending to protest about an incident that occurs in the racing area shall notify the Race Committee finish boat of her intention as soon as possible after finishing, identifying the boat(s) being protested. This changes rule 61.1(a)
- 16.3 Protests forms will be available at and returned to the protest box at the notice board.
- 16.4 The protest time limit is 60 minutes after the RC boat docks.
- 16.5 A protest hearing schedule and the location of the hearings will be posted on the official notice board no later than 15 minutes following the end of protest time.
- 16.6 Notice of actions taken by the race committee or protest committee and a list of boats penalized under Appendix P will be on the official notice board.
- 16.7 On the last day of the regatta a request for reopening a hearing shall be delivered:
- within the protest time limit if the party requesting reopening was informed of the decision on the previous day.
 - within the protest time limit, or 30 minutes after the decision is announced, whichever is later. This changes rules 62.2 and 66.

17 US SAILING REQUIREMENTS FOR AN AREA QUALIFIER REOPENING

- 17.1 Under rule 70.5(a), there shall be no appeal of the decision of a protest or request for redress. However, a decision following a hearing under rule 69.1(a) may be appealed. E-mail and phone contact information for each boat entered and for the chairmen of the protest committee and the race committee shall be posted on the official notice board at all times during the event.
- 17.2 Rule 65.2 is changed as follows:
- 65.2** A *party* to the hearing is entitled to receive the above information in writing, provided she asks for it in writing and hand-delivers her request to a member of the protest committee no later than the protest time limit on the last day of racing or one hour after being informed of the decision, whichever is later. The committee shall then, within two hours, hand-deliver the information to the *party*, including when relevant, a diagram of the incident prepared or endorsed by the committee.
- 17.3 Rule 66 is changed as follows:
- 66 REOPENING A HEARING 66.1 The protest committee may reopen a hearing when it decides that it may have made a significant error, or when significant new evidence becomes available within a reasonable time. A party to the hearing may ask for a reopening no later than 24 hours after being informed of the decision. When a hearing is reopened, a majority of the members of the protest committee shall, if possible, be members of the original protest committee and include at least one National Judge.

66.2 AREA QUALIFIER REOPENING

A party to a hearing of a protest or request for redress may request an Area Qualifier Reopening. The request shall be in writing and include the significant error that the party believes the protest committee made or the nature of the significant new evidence within a reasonable time. The request shall be made no later than 24 hours after the hearing or 24 hours after the protest time limit on the last day of racing, whichever is later. The request, along with copies of the original protest or request for redress, the facts found, the decision of the protest committee, any new evidence that cannot be presented verbally, and e-mail and phone contact information for all parties to the hearing as well as the chairman of the protest committee, shall be sent by e-mail to the US Sailing Championships Director, LizWalker@ussailing.org and the US Sailing Championships Chair, swmadero@aol.com.

(a) The hearing shall be reopened when the foregoing information is received by the Director and the Chair.

(b) The protest committee for an Area Qualifier Reopening shall consist of the chairman of the original protest committee plus four certified judges appointed by US Sailing. A majority of the committee's members shall be National or International Judges. The Championship Chair will appoint its chairman.

(c) An Area Qualifier Reopening will be conducted by telephone/VOIP conference call. The time and date for the conference call shall be established by the chairman as soon as practicably possible and no later than seven days after the request for reopening is e-mailed. The chairman will e-mail to the parties to the hearing the request for reopening, the facts found, the decision of the protest committee, the time and date of the hearing, the process for joining the call and any other relevant documents.

18 SCORING

18.1 The Low Point System of Appendix A will apply.

18.2 Three (3) races are required to be completed to constitute a series.

18.3 When fewer than five (5) races have been completed, a boat's series score will be the total of her race scores.

18.4 When five (5) or more races have been completed, a boat's series score will be the total of her race scores excluding her worst score. This changes rule A2.

19 REPLACEMENT OF EQUIPMENT

Substitution or repair or replacement of hulls, sails, or equipment will not be allowed without prior approval of the judges or the protest committee.

20 COACHING AND OUTSIDE CONTACT

This is a Grade 3 Event as defined in the US Sailing Championship Support Vessel Policy. See <http://www.ussailing.org/racing/championships/coaching-and-support-boats-policy/> For Grade 1 events, delete sections 23.2, 23.3 and 23.4

Except as provided in the Policy specified above, instructors, coaches and other support personnel and family members shall not go afloat in the defined racing area at any time during the clinic or racing days, except in spectator boats supplied by the regatta organizers.

20.1 Outside contact with competitors is prohibited on clinic and racing days commencing with the competitor's arrival at the host club and shall continue until dismissed by the National Coach on clinic days, or released by the Protest Committee on racing days.

20.2 Outside contact is defined as a parent, family member, spectator, or coach. Competitors shall not receive advice, instruction, or any type of outside assistance (other than that provided by US Sailing) including electronic communication devices while at the sailing venue during the clinic and racing days. It is the intent of this rule to prohibit contact between competitors and any person, who, in the opinion of the Protest Committee, is a coach, instructor or advisor.

20.3 Any coaches provided by US Sailing will offer individual on-the-water instruction and group commentary/advice on land following each racing day. This coaching will be given to all competitors on an as equal basis as possible.

- 20.4 The Protest Committee may protest and disqualify a competitor for breaking the rules of this sailing instruction from all races on the day of the infringement.

21 DISCIPLINE

- 21.1 For Junior and Youth events or for junior or youth competitors in any US Sailing championship, no participant or competitor shall use or possess, either on or off the water: marijuana or any other substance if possession is illegal under state or federal law; or any alcoholic beverages. US Sailing Regulation 10.
- 21.2 An alleged breach of one of these regulations shall not be grounds for a protest. However, when the protest committee believes that a competitor may have breached one of these regulations, it shall follow the process described in the Championships Code of Conduct. If a competitor found to have breached one of the elements within the Code of Conduct, they shall be excluded from the remaining races of the series and, where practicable, removed from the regatta venue and sent home. The competitor's boat shall be disqualified from all races of the series.

22 PRIZES

- 22.1 (For all Areas excluding H and L) The top team in the Triplehanded and the top two (2) scoring teams in the Doublehanded and Singlehanded divisions will qualify for the National Finals. Go to <http://championships.ussailing.org/Youth/ChubbJrChampionships.htm> for registration information.
- 22.2 OR
- 22.3 (for Areas H and L) The top team in each of the three divisions will qualify for the National Finals. Go to <http://championships.ussailing.org/Youth/ChubbJrChampionships.htm> for registration information.
- 22.4 Winners will receive US sailing medals.

Attachment B - Course Diagrams

23 WINDWARD-LEEWARD, 3 LEGS

Start at leeward mark, finish at windward mark

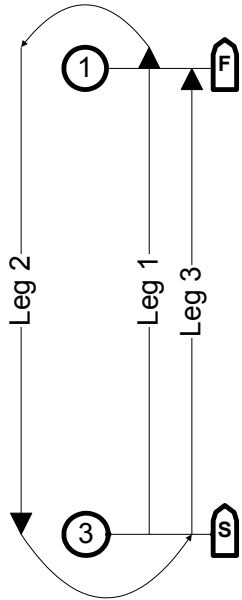

Offset start and finish lines

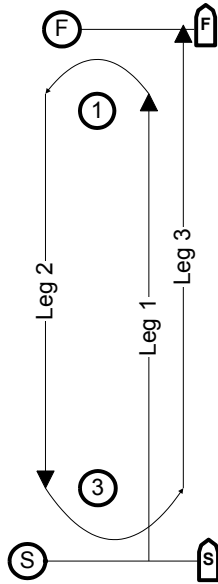

Mid-leg Start/finish lines

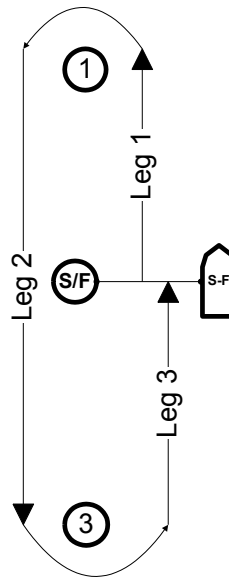

Triangle + Windward, 4 legs total

Start at leeward mark, finish at windward mark

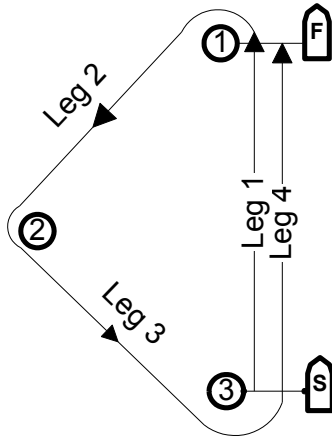

Offset start and finish lines

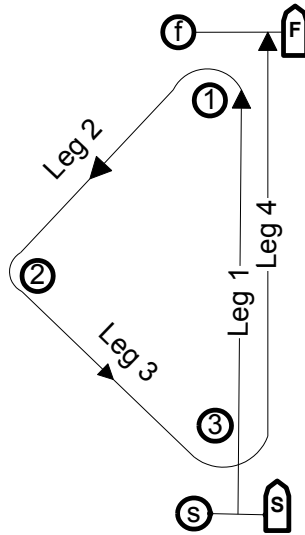

Mid-leg Start/finish

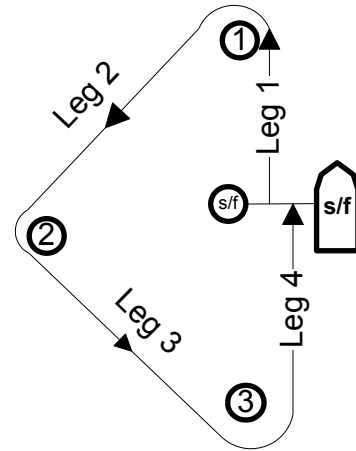

Triangle + Windward + Leeward (Gold Cup)

Start at leeward mark, finish at windward mark

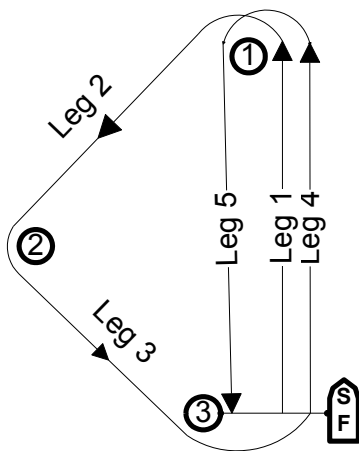

Offset start and finish lines

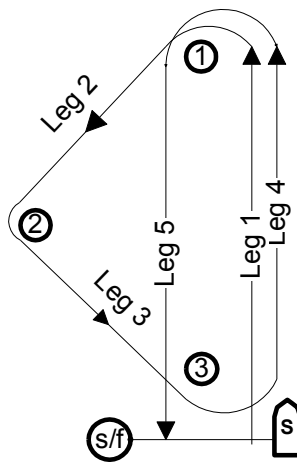

Mid-leg Start/finish

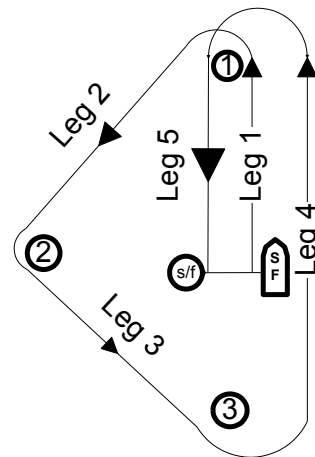

Triangle + Windward + Leeward + Windward (Olympic)

Start at leeward mark, finish at windward mark

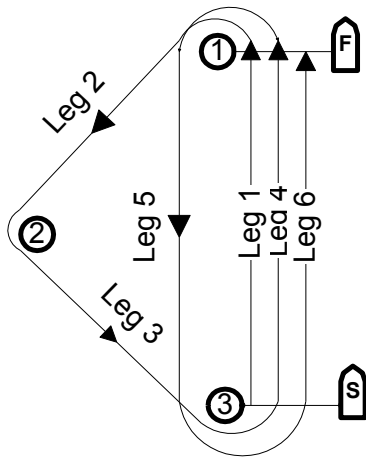

Offset start and finish lines

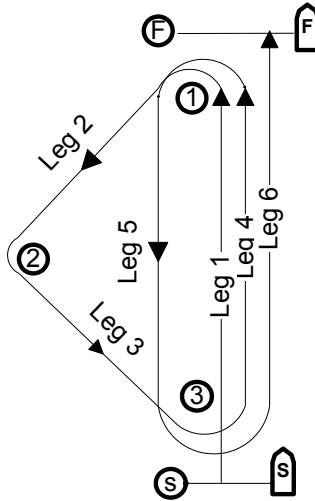

Mid-leg Start/finish

