

SAILING INSTRUCTIONS

2017 Outer Cape Invitational

Hosted by the Orleans Yacht Club

Tuesday, July 18th, 2017

Orleans Yacht Club | 39 Cove Road | PO Box 145 | Orleans, MA 02653 | (508) 255-9091

1 RULES

The regatta will be governed by the rules as defined in the current Racing Rules of Sailing (RRS).

2 NOTICES TO COMPETITORS

Notices to competitors will be posted in the tent area at the Orleans Yacht Club.

3 SIGNALS MADE ASHORE

3.1 Signals made ashore will be displayed on the OYC flagpole.

3.2 If a postponement is signaled ashore, the warning signal will be made not less than 45 minutes after AP is lowered.

4 SCHEDULE

Tuesday, 18 July

0800 Check-in & breakfast at OYC
0900 Skippers' meeting under OYC tent
0930 Harbor Start
1000 Approximate time of first race start
1400 No race start later than approximately this time
Lunch and awards to follow

5 RACING AREA

The racing area will be Orleans Town Cove

6 CHECK IN/CHECK OUT

6.1 When arriving at the race course, each competitor must check in with the race committee boat by passing astern of the race committee boat on a starboard tack and hailing their sail number until acknowledged.

6.2 Any sailor who decides to leave the race course prior to the conclusion of racing must check out with the race committee. This can be done by hailing the race committee boat directly or by alerting a coach boat, which will then alert the race committee via VHF radio.

7 MARKS

The pin will be an orange cylindrical mark. All other marks will be yellow tetrahedrons.

8 RACE COMMITTEE RADIO

The race committee and all coach boats will communicate on VHF channel 72.

9 COURSES

The diagrams in Attachment A show the courses, including the order in which marks are to be passed and the side on which each mark is to be left. The race committee may signal that

SAILING INSTRUCTIONS

more than one lap of a course is to be sailed by appending the number of laps to the course letter (e.g., "D2" for 2 laps of course D)

10 STARTING AND FINISHING LINES

10.1 The start/finish line will be between a mark and the flag-raising structure on the committee boat.

10.2 Races will be started per RRS 26 (5-minute start).

10.3 In case of an individual recall, Race Committee may choose to announce the sail numbers of recalled boats, but is not obligated to do so. Failure to hear such an announcement does not absolve a recalled boat of its responsibility to comply with RRS 29.1 or 30 (over early).

11 GATE IS OPEN

Boats **may** pass through the start/finish line during a race other than to start or finish.

12 PROTESTS

12.1 A boat wishing to protest another boat shall:

12.1.1 Hail the other boat at the first reasonable opportunity

12.1.2 Conspicuously display a red flag (attachment to 420 side-stay suggested) at the first reasonable opportunity, and display the flag for the remainder of the race and until the race committee instructs the flag to be lowered. This changes RRS 61.1(a)(2).

12.1.3 Report the protest to the Race Committee at the first reasonable opportunity, including the sail number(s) of the boat(s) being protested (usually, following the conclusion of the race).

12.2 Protests shall be delivered to the Principal Race Officer within **30** minutes after the Race Committee boat docks. The protest time limit and a list of protests received will be posted on the notice board. Hearings will be held as soon as possible after racing concludes.

12.3 All protests will be heard by coaches of sailors **not involved** in the protest, whether such sailors are protesting or being protested. The Principal Race Officer reserves the right to select the protest committee.

13 SCORING

13.1 The Low Point System of RRS Appendix A will apply.

13.2 One race constitutes a series.

13.3 For every five races sailed, one race will be excluded from each boat's series score (e.g., if ten races are sailed, two races will be excluded).

14 TROPHIES

14.1 The skipper and crew of the top three boats will receive trophies.

14.2 Trophies will also be awarded to the skipper and crew of the boat which finishes in the middle position; that is, with an equal number of boats finishing ahead and behind it in the final standings.

SAILING INSTRUCTIONS

ATTACHMENT A: COURSE DIAGRAMS

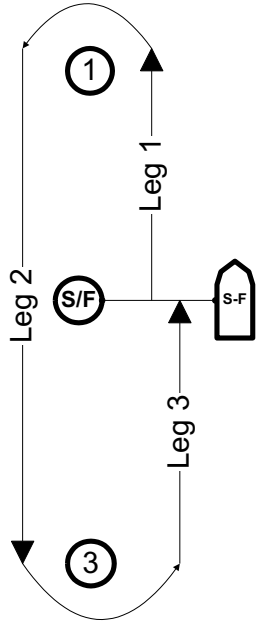

D

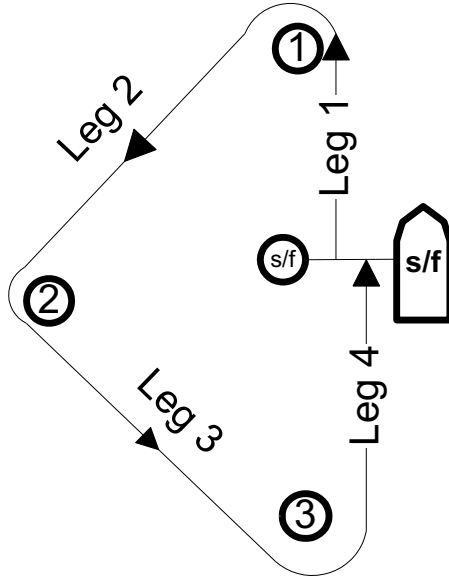

M

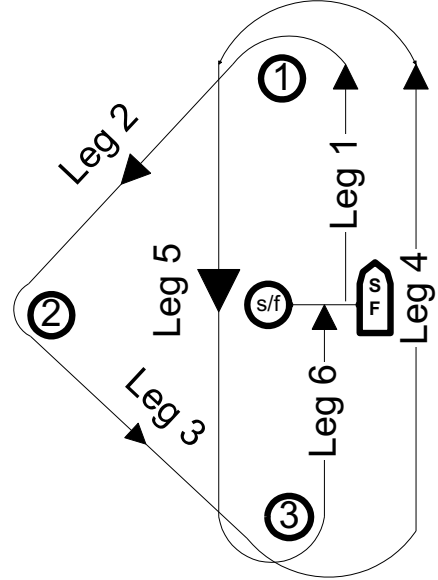

F