

**South Jersey Summer Series
GWYC/YCSIC Midsummer Regatta
July 6, 2017
Sailing Instructions**

1. RULES

The regatta will be governed by the rules as defined in the United States Sailing Association's Racing Rules of Sailing 2017-2020, the South Jersey Summer Series Rules and Regulations, Notice of Race, and by these sailing instructions.

2. NOTICES TO COMPETITORS

Notices to competitors will be posted on the window by the deck door of the GWYC club house.

3. ALTERATION OF RACING RULES

- 3.1 RRS 62.2 is changed to read, "The request shall be made in writing within the time limit of RRS 61.3. The protest committee shall extend the time if there is good reason to do so.

4. ELIGIBILITY AND ENTRY

- 4.1 Refer to SJSS Rules and Regulations 2017, section 5, for Eligibility requirements
4.1 Eligible boats may enter by completing the registration form and paying associated fees.

5. CHANGES TO THE SAILING INSTRUCTIONS

Any change to these sailing instructions will be posted on the Official Regatta Notice Board not later than 8:30 AM on the day of the regatta.

6. SIGNALS MADE ASHORE

In accordance with RRS 90.2 (c), oral changes to the Sailing Instructions may be made on the water. A change is in effect when the Race Committee boat displays code flag L with one sound signal. This means come within hail of the Race Committee boat to receive the oral change to the Sailing Instructions.

7. SCHEDULE OF RACES

- 7.1 Racing is scheduled as follows:
9:00 420s, Lasers & Sunfish, 9:30 Opti Red, White, Blue, 10:00 Green Fleet
7.2 No warning signal will be made after 12:30.

8. CLASS FLAGS

Division (class) Signals will be announced during the Competitors' Meeting.

1. 420 Club Dinghy
2. Laser Radial
3. Laser 4.7
4. Sunfish
5. Optimist (Red, White, Blue, Green)

The Race Committee may combine classes with another class for the purpose of a start.

9. RACING AREA The racing area for all fleets will be in Sunset Lake.

10. THE COURSES

- 10.1 The diagrams in Attachment A show the courses to be sailed including the approximate angle between legs, the order in which the marks are to be passed and the side on which each mark is to be left. The race committee reserves the right to use alternate courses if conditions warrant it.
- 10.2 No later than the warning signal, the race committee signal boat will display the course.

11. MARKS

- 11.1 The marks will be defined at the Skipper's meeting for each course.

12. THE START

- 12.1 Races will be started using a three (3) minute dinghy start as provided in the RRS Appendix U Sound Signal Starting System.
- 12.2 The starting line will be between a staff displaying an orange flag on the race committee boat at the starboard end of the line and the orange pin marking the port end of the starting line.
- 12.3 A committee boat that is also a starting mark may set a limit mark. A boat shall not touch either the limit mark or the committee boat or pass between them. For purposes of RRS 31 and RRS 28, the limit mark and the committee boat shall be considered to be a single starting mark.
- 12.4 Boats whose warning signal has not been made shall avoid the starting area.
- 12.5 A boat starting later than 5 minutes after her starting signal will be scored Did Not Start.
- 12.6 The order of start for the first race of the day will be announced at the skippers' meeting and posted on the official notice board. Subsequent races may be started in any order.
- 12.7 Contestants not starting a race shall notify the race committee or an official patrol boat of such intent. Coaches may also relay the decision by a sailor not to start a race.

13. COURSE CHANGES

- 13.1 Shortening of a course or changing the direction of a leg shall be performed in accordance with RRS 32 and RRS 33 accordingly.

14. THE FINISH

- 14.1 The finishing line will be between a staff displaying an orange flag on a race committee boat and the finish mark.
- 14.2 A boat which does not finish or retires from a race shall notify the race committee before leaving the course area or, if that is impossible, immediately after arriving ashore.
- 14.4 After finishing, boats shall stay clear of the finish line. Boats that have finished may begin to sail towards the starting line as long as they remain outside of the racing area, unless the race committee indicates otherwise.
- 14.5 The protest committee may, without a hearing, penalize a boat that has broken RRS 42.

15. PENALTY SYSTEM

- 15.1 The penalty system for this regatta shall follow RRS 44.1 (taking a penalty) and 44.2 (One-Turn and Two-Turns Penalties)
- 15.2 Any boat taking a penalty shall inform the committee at the finish line and receive a verbal acknowledgment from the committee.

16. TIME LIMIT

- 16.1 Time limit is sixty (60) minutes for the first boat to finish.
- 16.2 Boats failing to finish within thirty (20) minutes after the first boat in her class sails the course and finishes will be scored Did Not Finish. This changes RRS 35. At their discretion, the Race Committee may finish a boat in place within the time limit.

17. PROTESTS AND REQUESTS FOR REDRESS

- 17.1 RRS 61.1 (a) is modified such that a boat intending to protest shall notify the race committee at the finish line, giving the name and sail number of the boat being protested.
- 17.2 Protest forms are available at the registration desk.
- 17.3 The time limit to file a protest for all classes is thirty (30) minutes after docking of the race committee finish boat for the division involved. The same time limit applies to all protests filed by the race committee and requests for redress. This changes RRS 61.3 and 62.2.
- 17.4 Hearings will be held in the upper room at GWYC or other suitable location on the grounds.

18. SCORING

- 18.1 The Low Point Scoring System RRS A and SJSS Rules and Regulation 2017, section 10 apply.
- 18.2 Five races are scheduled.
- 18.3 One race shall constitute a series.
- 18.4 No score will be excluded.
- 18.5 RRS A8.2 is revised to read: If a tie still remains between two or more boats, they shall be ranked in order of their scores in the last race in which they both competed, head to head.

19. SAFETY REGULATIONS

- 19.1 Each boat shall check-in with the race committee on the water prior to the first race of the day.
- 19.2 SJSS Rules and Regulations 2017 section 8.A shall apply with regard to Personal Flotation Devices (PFDs).

20. REPLACEMENT OF CREW OR EQUIPMENT

Substitution of competitors and equipment will not be allowed without prior written approval of the race committee. Substitution of damaged or lost equipment will not be allowed unless approved by the race committee. Requests for substitution shall be made to the committee at the first reasonable opportunity.

21. OFFICIAL BOATS

Official boats will be marked by display of Race Committee Flags.

22. COACHING

Refer to SJSS Rules and Regulations 2017 section 7G for limitations on coaching.

23. ADDITIONAL PRESCRIPTIONS

- 23.1 Sail numbers shall agree with the boat's registration number.
- 23.2 Boats observed discharging waste or trash over the side shall either be disqualified from all races sailed on the day of the infraction or be subject to other disciplinary action or both.

24. PRIZES

Optimist Green Fleet: All participants will receive a participation award

Optimist: 1st-5th place for Red, Blue and White fleets

Sunfish: 1st-5th place

Laser 4.7: 1st-5th place

Laser Radial: 1st-5th place

Club 420: 1st-5th place for skipper and crew

25. DISCLAIMER OF LIABILITY

Competitors participate in the regatta at their own risk. See RRS 4, Decision to Race. The organizing authority will not accept any liability for material damage or personal injury or death sustained in conjunction with or prior to, during or after the regatta.

GWYC/YCSIC Midsummer Regatta Courses

"T4"

Order: Start – 1 – 2 – 3 – Finish

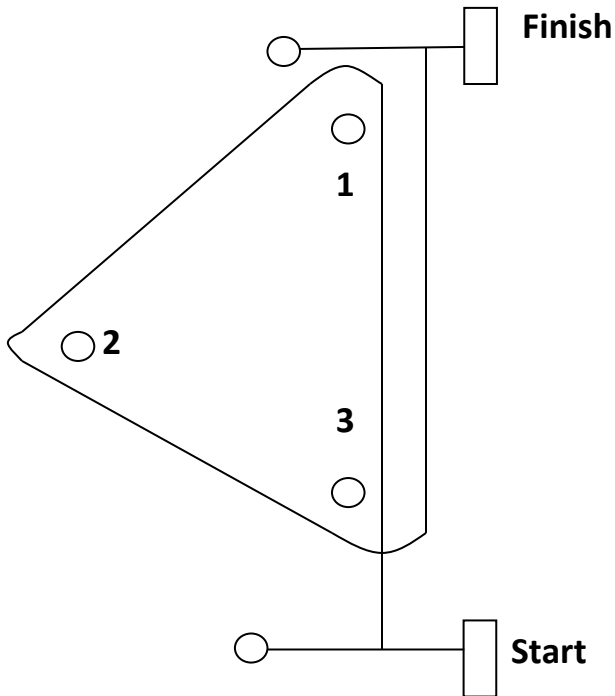

"O"

Order: Start – 1 – 2 – 3 – 1 – 3 - Finish

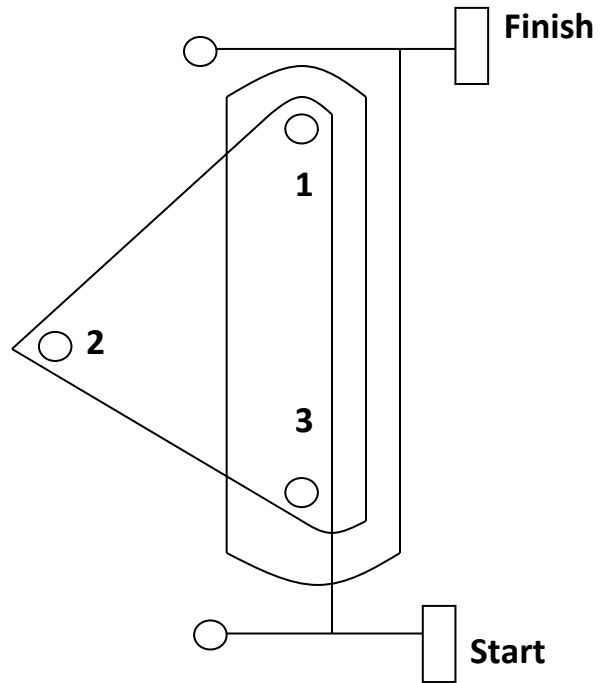

"W3"

Order: Start – 1 – 2 – Finish

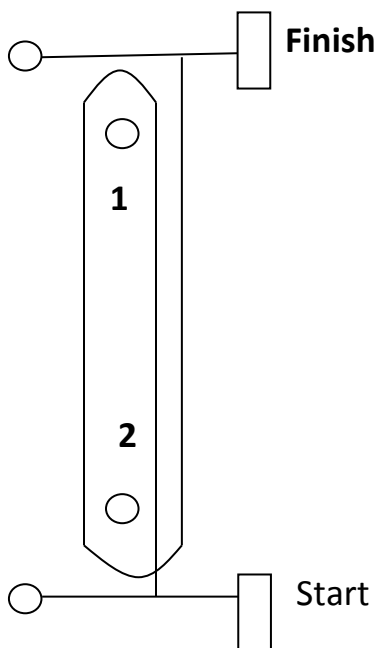

"W5"

Order: Start – 1 – 2 – 1 – 2 – Finish

