



YACHT CLUB of STONE HARBOR
Mid-Atlantic Yacht Racing Association
SJSS Jr. Midweek Regatta
Sailing Instructions
Invitational Dinghy Regatta Thursday, July 13, 2017

1. RULES

- 1.1 The regatta will be governed by the rules as defined in The Racing Rules of Sailing.
- 1.2 The prescriptions of the Mid Atlantic Yacht Racing Association.

2. NOTICES TO COMPETITORS

Notices to competitors will be posted on the official notice board is located in the Grille Room.

3. ALTERATION OF RACING RULES

- 3.1 RRS 62.2 is changed to read, "The request shall be made in writing within the protest time limit.
- 3.2 RRS A8.2 is changed for the purpose of MAYRA Seasonal Scoring (ONLY) to read, "If a tie still remains between two or more boats, they shall be ranked in order of their scores in the last race of the club regatta series in which they both competed, head to head."

4. ELIGIBILITY AND ENTRY

- 4.1 Eligible boats may enter by completing registration with the registration authority.
- 4.2 All sailors, even if pre-registered, **MUST** check-in upon arrival at the Club.
- 4.3 A minimum of three (3) boats is required for a separate fleet start. A boat is required to come to the starting area, start, sail the course and finish the minimum number of races specified in Instruction 18.1.

5. CHANGES TO SAILING INSTRUCTIONS

Any change to the sailing instructions will be posted before **0900 hrs** on the day it will take effect, except that any change to the schedule of races will be posted by **1700 hrs** on the day before it will take effect.

6. SIGNALS MADE ASHORE

- 6.1 Signals made ashore will be displayed at the Club's signal mast.
- 6.2 AP' 1 minute is replaced with 'not less than **20 minutes**' in race signal AP
- 6.3 'L' Important message posted.

7. SCHEDULE OF RACES

- 7.1 Racing is schedules as follows:

<i>Date</i>	<i>Class</i>
Thursday, July 13	

Course 1 (North Course) Club 420 & Laser Radial

Course 2 (Middle Course) Laser 4.7 and Sunfish

Course 3 Optimist (red, blue, white)

Course 4 YCSH Channel Dock-Optimist Dinghy (Green Fleet)

- 7.2 Skippers meeting will take place at **0900 hrs** on the race day.
- 7.3 The **scheduled** time of the warning signal for the first race is **1015 hrs for course 1, 2 & 3** and Green Fleet Optimist.
- 7.4 No warning signal will be made after **1400 hrs**.

8. CLASS FLAGS

Division (class)	Signals
1 420 Club	Class Flag
2 Optimist	Class Flag
3 Laser (all)	Class Flag
4 Sunfish	Class Flag

9. RACING AREA

Attachment 'A' shows the location of the racing areas.

10. THE COURSES

10.1 The diagrams in the Attachment with labels 'B', 'C', 'D' and "E" show the courses, including the order in which marks are to be passed and the side on which each mark is to be left.

10.2 No later than the warning signal, the race committee signal boat will display the course of each class. The first mark will be upwind of the starting line.

11. MARKS

11.1 Marks for all courses will be inflatable buoys.

12. THE START

12.1 Races will be started using RRS S3.

12.2 The starting line will be between a staff displaying an orange flag on the starting mark at the starboard end and an inflatable mark at the port-end of the line.

12.3 Check-in: Before the warning signal of the first race to start, all boats shall sail past the stern of the committee boat and hail her class and sail number, which hail will be acknowledged by the race committee. A boat failing to do so may be notified of a breach of the rules and may receive a 20% penalty.

12.4 Boats whose warning signal has not been made shall avoid the starting area.

12.5 A boat starting later than **3 minutes** after her starting signal may be scored (DNS) Did Not Start. This changes RRS A4.1.

12.6 When a general recall has been signaled, the start(s) for other classes will be postponed accordingly.

12.7 RECALLS: As a courtesy the Race Committee will attempt to hail the sail numbers of OCS boats. The failure of any boat to hear her hail, or the timing and order of such hails shall not be grounds for granting redress. This changes RRS 62.1.

12.8 Contestants not starting in a subsequent race shall notify the race committee of such intent.

13. THE FINISH

13.1 The finishing line will be between a staff displaying an orange flag on a race committee boat and a finish mark.

13.2 Check-in: A boat which does not finish or retires from a race shall notify the race committee before leaving the course area or if that is impossible, immediately after arriving ashore.

13.3 The race committee will attempt to run five races, however, one race constitutes a regatta.

14. TIME LIMIT

14.1 Time limits are **sixty (60) minutes** for each class.

14.2 If no boat has passed Mark 1 within fifteen (**15) minutes** of her class start the race will be abandoned.

14.3 Boats failing to finish within **ten (10) minutes** after the first boat in her class sails the course and finishes shall be scored **Did Not Finish**. This changes RRS 35 and RRS A4.

15. PROTESTS AND REQUESTS FOR REDRESS

15.1 RRS 61.1(a) is modified in that a boat intending to protest shall attempt to notify and receive acknowledgement from the race committee at the finish line giving the name and number of the boat being protested.

15.2 Protest forms are available at the registration/scoring desk. Protests shall be delivered there within the time limit.

15.3 For all classes, the Protest and redress time is **thirty (30) minutes** after the docking of the race committee finish boat for the division involved. The same protest time limit applies to all protests by the race committee. This changes RRS 61.3 and 62.2.

15.4 Notices will be posted within **thirty (30) minutes** of the protest time limit to inform competitors of hearings in

which they are parties or named. Hearings will be held in the Club's Board Room.

15.5 Notices of protests by the race committee or protest committee/jury will be posted to inform boats under RRS 61.1(b).

15.6 Breaches of instructions 12.4; 12.8; 14.2; will not be grounds for a protest by a boat. This changes RRS 60.1(a). Penalties for these breaches may be less than disqualification if the protest committee/jury so decides.

15.7 A request for reopening a hearing shall be delivered no later than 30 minutes after the party requesting reopening was informed of the decision on that day. This changes RRS 66.

15.8 Appeals will be heard by the MAYRA Appeals Committee.

15.9 Penalties at the time of an incident will be handled under Rules 44.1 and 44.2 with regard to one and two-turn penalties.

16. SCORING

16.1 The Low Point Scoring System RRS Appendix A. Five races are scheduled in each club's regatta (series) of which a minimum of one (1) race shall be completed to constitute a regatta series and award of MAYRA seasonal points.

16.2 Each boat's regatta score shall be the total of all races. No score will be excluded.

17. SAFETY REGULATIONS

17.1 Each boat shall be equipped with a 20 foot line for towing.

17.2 All C-420's will be equipped with an approved masthead flotation device to prevent it from turning turtle.

18. REPLACEMENT OF CREW OR EQUIPMENT

18.1 Substitution of competitors and equipment will not be allowed without prior written approval of the race committee, protest committee, or jury. Substitution of damaged or lost equipment will not be allowed unless approved by the race committee. Requests for substitution shall be made to the committee at the first reasonable opportunity.

19. EQUIPMENT AND MEASUREMENT CHECKS

19.1 A boat or equipment may be inspected at any time for compliance with the class rules and sailing instructions. On the water a boat can be instructed by a race committee measurer to proceed to a designated area for inspection.

20. OFFICIAL BOATS

20.1 Official boats will be marked by display of the R/C flag.

21. SUPPORT BOATS

21.1 Coaches and other support personnel shall stay outside of areas where boats are racing and outside of 100' of any contestant from the time of the preparatory signal for the first race class to start until all boats have finished or the race committee signals postponement, general recall or abandonment. The penalty for failing to comply with this requirement shall be 20% of the boats registered in each class for all boats associated with the support personnel.

21.2 The USODA Green Fleet policy applies.

21.3 Coaching of Green Fleet skippers while racing is permitted, however coaching shall be limited to skippers in the bottom half of the fleet in any given race. Only boats which have registered with the organizing authority and carry identification satisfactory to the organizing authority will be allowed to be in the race area.

21.4 Coach boats shall neither create wakes nor otherwise interfere with competitors. Coaches shall provide fair and consistent support to all competitors, not just their team or sailor. Violation of this instruction may result in any penalty that the jury deems appropriate, up to, and including disqualification of the coached skipper from the regatta.

22. MAYRA PRESCRIPTIONS

22.1 Any entry not displaying the assigned class or association number, or without the prior approval of the Race Committee or Jury may be penalized as per RRS 77 and Appendix G. Sail numbers shall agree with the boat's registration number.

22.2 Life Jackets or Personal Flotation Devices must be worn at all times while on the water and be of the type approved by the United States Coast Guard.

22.3 RRS 40 (Personal Buoyancy) and RRS 43 (Competitors Clothing and Equipment) apply to all dinghy racing.

22.4 All boats are required to carry all safety equipment as required by their class, national, state and local regulations.

22.5 Boats observed discharging waste or trash over the side shall either be disqualified from all races sailed on the day of the infraction or be subject to other disciplinary action or both.

23. PRIZES / TROPHIES

Prizes will be presented following the last race and in accordance with MAYRA Dinghy Fleet Definition and Trophy Recommendations – 2011.

24. DISCLAIMER OF LIABILITY – Competitors participate in the regatta at their own risk. See RRS 4, Decision to Race. The organizing authority will not accept any liability for material damage or personal injury or death sustained in conjunction with or prior to, during or after the regatta.

25. RESPONSIBILITY – The responsibility for supervising any regatta is solely that of the sponsoring club or organization The Mid Atlantic Yacht Racing Association assumes no liability in connection therewith. The responsibility of the Race Committee is to provide a start and to record times and/or positions at the finish. The decision to start, continue or retire is the responsibility of the contestant.

Attachment's A

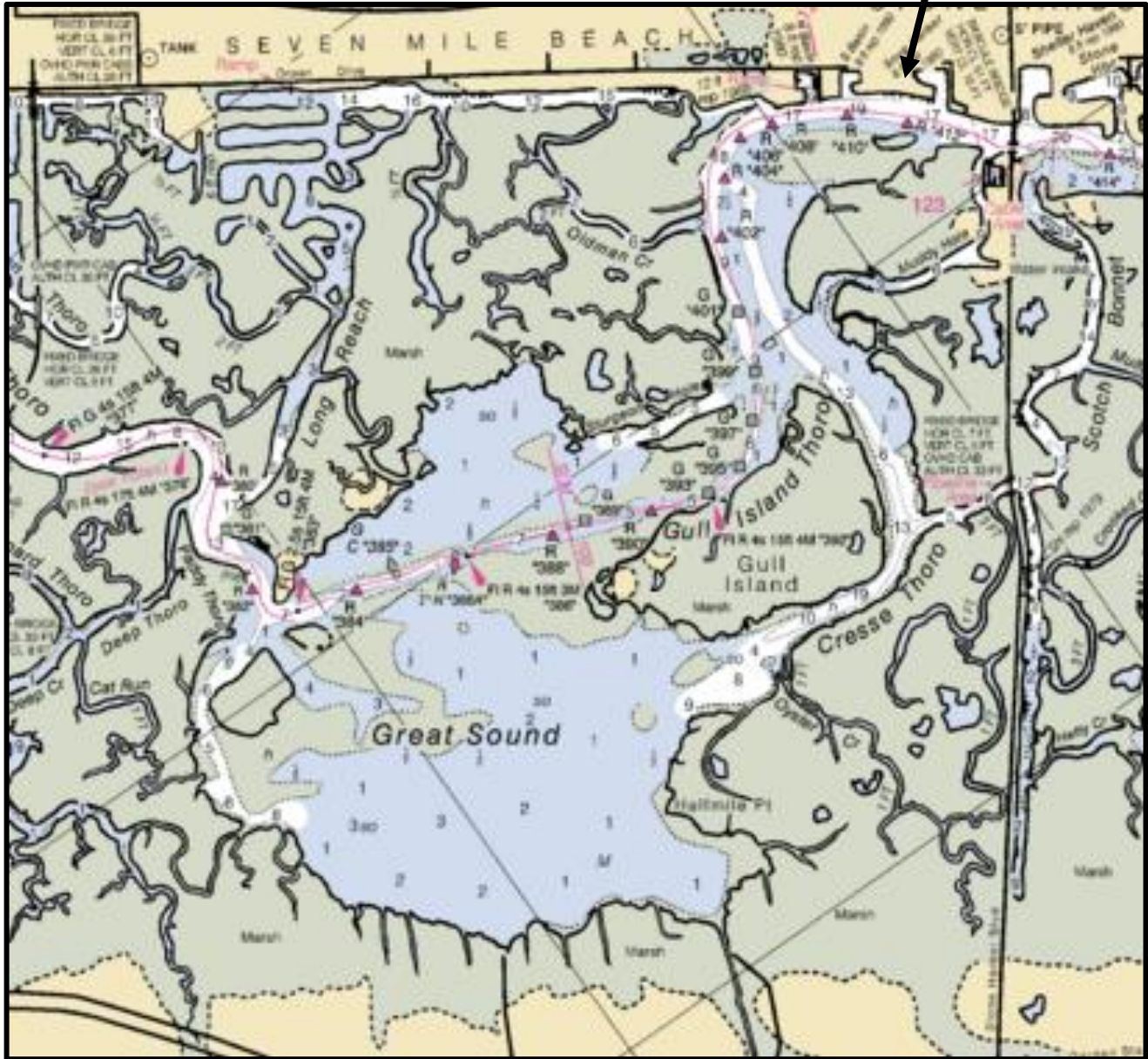

MAYRA SJSS JR. REGATTA COURSES

B.

"T4"

Order: Start - 1 - 2 - 3 - Finish

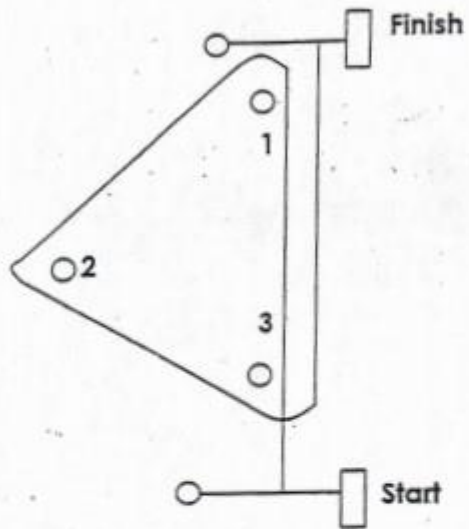

C.

"O"

Order: Start - 1 - 2 - 3 - 1 - 3 - Finish

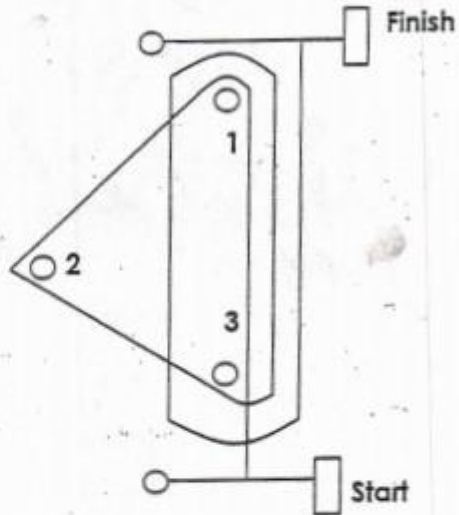

D.

"W3"

Order: Start - 1 - 2 - Finish

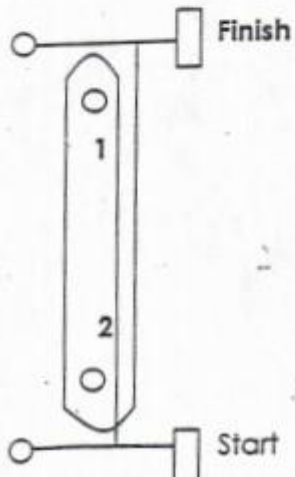

E

"W5"

Order: Start - 1 - 2 - 1 - 2 - Finish

