



52nd ANNUAL
DON Q. RUM KEG SNIPE REGATTA
MARCH 23-25, 2018
COCONUT GROVE SAILING CLUB, AND SNIPE FLEET 7
SPONSORED BY DESTILERIA SERRALLES
SAILING INSTRUCTIONS



1. RULES:

- 1.1. The race will be governed by the rules as defined in the Racing Rules of Sailing (RRS).
- 1.2. The following Prescriptions of US Sailing are the only Prescriptions that will apply: Appendix R and prescriptions to rules 60.3, 61.4, 63.2, 67 and 76.1.
- 1.3. Each Snipe racing in this event must have aboard life-saving equipment conforming to government regulations in either the USA or the home country of each of the sailors aboard.
- 1.4. The following Racing Rules are being amended in these Sailing Instructions: 27.1; 30.4; 32; 33; 35; 44.3(c); 61; 62.2; 63.7; Appendix A2; Appendix A4; Appendix A5; Appendix A11; and Race Signals.
- 1.5. Advertising is permitted as per Snipe Class Rules. Boats may be required to display advertising chosen and supplied by the Organizing Authority.
- 1.6. Did Not Finish (DNF) is changed to Disqualification (DSQ) in RRS 44.3(c).
- 1.7. Black Flag shall not be used. This deletes RRS 30.4.
- 1.8. RRS 63.7 shall be replaced by – “If there is a conflict between the Notice of Race (NOR) and the Sailing Instructions (SIs), the Sailing Instructions shall apply.” This changes RRS 63.7.
- 1.9. If there is a conflict between languages the English text will take precedence.

2. NOTICE TO COMPETITORS:

- 2.1. Notices to competitors will be posted on the official regatta notice board located in the lower level of the Coconut Grove Sailing Club (CGSC).

3. CHANGES TO SAILING INSTRUCTIONS:

- 3.1. Any change or amendment to the Sailing Instructions will be posted before 0800 on the day it will take effect, except that any change in the schedule of races will be posted by 1900 hours on the day before it will take effect.
- 3.2. Any change or amendment to the Sailing Instructions will have the prior approval of the PRO or the SCIRA Representative.

4. SIGNALS MADE ASHORE:

- 4.1. Signals made ashore will be displayed at the CGSC flag hoist.
- 4.2. When Flag AP is displayed ashore, “1 minute” is replaced with “not less than ninety (90) minutes” in the race signal AP. This changes Race Signals.

5. SCHEDULE OF RACES:

- 5.1. No more than eight (8) races are scheduled. The warning signal for the first race scheduled each day is as follows:
 - a) Friday, March 23, 2018 Warning Signal for the first warning of the day at 1200.
 - b) Saturday March 24, 2018 Warning Signal for the first warning of the day at 1200.
 - c) Sunday, March 25, 2018 Warning Signal for the first warning of the day at 1100
- 5.2. Maximum of three (3) races per day.
- 5.3. No warning signal will be made after 1430 hours on Sunday.

6. CLASS FLAG:

- 6.1. The Class Flag will be a white flag with the Snipe insignia/emblem.

7. RACING AREA:

- 7.1. The Racing Area location is in Biscayne Bay in the vicinity of the entrance to Brennan’s Channel.
- 7.2. The distance and direction from the harbor to the racing area is approximately 2 nautical miles in an easterly to south easterly direction.

8. COURSES:

- 8.1. The diagram in Attachment “A” shows the courses, including the approximate angles between legs, the order in which the marks are to be passed, and the side on which each mark is to be left. The course length will be based on sailing conditions.

- 8.2. No later than one minute before the warning signal, the Race Committee signal boat will display the course to be sailed using code flag “O” for the Olympic course, code flag “T” for the Triangle course, and course flag “W” for the Windward Leeward course with all of the aforementioned courses finishing to windward. Courses to be sailed finishing downwind use code flags “OD” for the Olympic course, code flags “TD” for the Triangle course, and course flags “WD” for the Windward Leeward course. This changes RRS 27.1.
 - 8.3. The course flag(s) will be accompanied by one horn signal when raised and will remain displayed for ten minutes after the start. Timely removal of course flag shall not be grounds for redress. This adds to RRS 27.1.
 - 8.4. The approximate compass bearing and distance to Mark 1 shall be displayed by a numerical posting on a board on the Race Committee signal boat before the Preparatory signal.
 - 8.5. All marks shall be left to port unless it is a gate or the “start/finish mark” when finishing.
9. **MARKS:**
- 9.1. Marks 1, 2 and 3 shall be orange tetrahedrons.
 - 9.2. Start/finish mark (Mark S) shall be a yellow tetrahedron or a staff displaying an orange flag or shape on a Race Committee boat.
 - 9.3. New marks as provided in RRS 33 shall be yellow tetrahedrons, with the exception of the offset mark which, if replaced, will be a yellow ball.
 - 9.4. For the Windward/Leeward course(s) (course “W” or “WD”), an orange ball will be set as an offset mark approximately four (4) boat lengths adjacent and to port of Mark 1 and a leeward gate will replace Mark 3 (leeward). The two marks forming the gate will be located approximately seven boat lengths apart. In the event a single Mark 3 is established instead of a Gate (3s/3p) the single mark shall be left to port.
 - 9.5. Mark 3 is not a mark of the course when completing the second lap of courses “WD”, “TD”, or “OD”.
10. **THE START:**
- 10.1. The starting line will be between a staff displaying an orange flag on the Race Committee boat at the starboard end and the course side of a port-end start/finish mark or a staff displaying an orange flag on a Race Committee boat.
 - 10.2. Boats starting later than ten (10) minutes after their starting signal will be scored Did Not Start (DNS) without a hearing. This changes RRS 35.
 - 10.3. The starting line shall be set approximately 30 meters downwind of Mark 3 (leeward). Mark 3 is not a mark of the course for the first leg of the race.
11. **CHANGE OF COURSE OR NEXT LEG OF THE COURSE:**
- 11.1. Shortening or lengthening the next leg of the course shall not be by more than 30% of the original leg length. This changes RRS 33.
 - 11.2. The number of legs of the course shall not be reduced until after the second upwind leg. This changes RRS 32.
 - 11.3. Except at a gate, boats shall pass between the Race Committee boat signaling the change of the next leg and the nearby mark leaving the mark to port and the Race Committee boat to starboard.
 - 11.4. If during a race the wind and/or wave action change to the point where the course would be inadvisable (See Course Selection Diagram), the Race Committee can change the course to a “T”, “O”, or “W” by displaying the appropriate course flag accompanied by repetitive sounds at any mark. This changes RRS 33.
 - 11.5. When a change of course according to SI 11.4 is displayed the finish line will continue to be the same as the original course finish line. The Committee will **not** display code flag “D” when indicating a change of course which originally had a downwind finish.
12. **THE FINISH:**
- 12.1. For courses “W”, “T”, and “O”, the finish line shall be between a staff displaying an orange flag on a race committee boat at the starboard end and the course side of Mark “1” at the port-end.
 - 12.2. For courses “WD”, “TD”, and “OD”, the finish line shall be between a staff displaying an orange flag on the Race Committee boat at the port end and the course side of a starboard-end start/finish mark or a staff displaying an orange flag on a Race Committee boat.
 - 12.3. If the Race Committee intends to start another race on the same day, it will display flag Romeo “R” (with no sound) as boats are finishing. Flag Romeo “R” will be lowered with one sound signal one minute before the Warning Signal for the next race.
13. **PENALTIES:**
- 13.1. Any competitor taking a penalty in accordance with RRS 44.1 or 44.2 should notify the Race Committee promptly upon finishing that race and should also inform the Race Committee of the identity of the other boat involved.
 - 13.2. The Race Committee will post a list of Race Committee Actions prior to the end of the protest time limit (See SI 15.2, below.)

- 13.3. Bow numbers will be assigned at registration and it shall be each competitor's sole responsibility to properly affix them in conformance with the instructions in the registration packet and to properly maintain them. Any boat that is determined by the Race Committee to have violated this rule may be assessed the same penalty as a Check-In Failure (CNF) for the first race competed in by the infringing boat on the day of the infraction without a hearing.
 - 13.4. Any boat failing to check-in, in accordance with 17.1 and 17.2, shall be given a 10% penalty and scored CNF for the first race competed in by the infringing boat on the day of the infraction calculated as stated in rule 44.3(c). This changes RRS Appendix A5 and RRS Appendix A11.
 - 13.5. A boat that did not finish shall be scored DNF by the Race Committee without a hearing and shall be scored points equal to one more than the number of finishers. This changes RRS Appendix A4.
 - 13.6. The Race Committee Signal Boat will attempt to post the bow numbers of boats identified as OCS and ZFP during the previous start. Failure to post will not be grounds for redress.
- 14. TIME LIMIT:**
- 14.1. The time limit for the first boat to finish shall be one (1) hour thirty (30) minutes. Should the first boat fail to finish within the aforementioned time the Race Committee shall abandon the race.
 - 14.2. Should the first boat fail to complete the first lap within 45 minutes, the Race Committee shall abandon the race. For the purpose of this Rule a lap shall mean the rounding of mark 3 for the first time.
 - 14.3. Boats failing to finish within twenty (20) minutes after the first boat sails the course and finishes will be scored a DNF (1 point more than the number of boats finishing within the time limit) without a hearing. This changes RRS Appendix A4, and RRS Appendix A5.
- 15. PROTEST AND REQUEST FOR REDRESS:**
- 15.1. In addition to the requirements in RRS 61, a competitor's intent to protest should be reported to the Race Committee promptly upon finishing the race in which the incident occurred. This changes RRS 61 Protest forms will be available at the protest desk in the lobby of CRYC.
 - 15.2. Protests shall be delivered to the protest desk within the protest time limit of one (1) hour after the race committee signal boat docks.
 - 15.3. Notices of protests and the hearing schedule will be posted on the official notice board at CGSC within 10 minutes after the protest time limit.
 - 15.4. Notices of protests by the RC or Protest Committee will also be posted on the official notice board no later than 10 minutes after the protest time limit to inform boats under RRS 61.1b.
 - 15.5. On the last scheduled day of racing, a request for redress based upon a protest committee decision or scoring, including starting penalties, shall be delivered no later than 30 minutes after the information was posted, or the protest time limit, whichever is later. This changes RRS 62.2
 - 15.6. In accordance with RRS 64.1, The protest committee may impose penalties of less than DSQ for breaking rules other than RRS Parts 2 and 3.
- 16. SCORING:**
- 16.1. One race is required to be completed to constitute a series.
 - 16.2. The Low Point Scoring System shall be used as amended by these Sailing Instructions.
 - 16.3. A boats series score will be the total of her race scores when five or less races are completed. This changes RRS Appendix A2.
- 17. SAFETY REGULATIONS:**
- 17.1. Each day, before the start of a competitor's first race of the day, each boat is required to sail on starboard tack past the stern of the Race Committee Signal boat and verbally check in.
 - 17.2. When the Race Committee verbally acknowledges a boat's bow number, the check-in has been officially noted.
 - 17.3. A boat that retires from a race shall notify the Race Committee as soon as possible.
- 18. REPLACEMENT OF CREW:**
- 18.1. The same crew shall race in all races, except for reasons satisfactory to the Race Committee.
 - 18.2. Requests for the replacement of any member of the crew shall be submitted in writing to the PRO prior to 0900 on the day the change will take effect.
 - 18.3. The request for replacement of any member of the crew requires the approval of the PRO.
 - 18.4. Once a skipper and/or crew have been excused, they may not return for the balance of the series.
 - 18.5. Co-skippers shall be allowed subject to the restrictions of 18.1 and 18.2.

19. EQUIPMENT AND MEASUREMENT CHECKS:

19.1. The Race Committee may inspect competitors or boats at any time before or after racing. Equipment inspections may be initiated at the finish of any race.

20. SUPPORT BOATS:

20.1. No coach, other support or spectator vessels shall be within 100 yards of the race course except to render assistance. Any competitor associated with personnel determined to have violated this rule shall be subject to protest and assessed a 20% penalty for the race in which the violation occurred.

21. PRIZES:

21.1. Prizes shall be awarded to the skipper and crew for the top ten places.

22. QUALIFICATION FOR FUTURE EVENTS:

22.1. The top 2 eligible US boats will qualify for the 2019 SCIRA World Championship.

23. DISCLAIMER OF LIABILITY:

23.1. Competitors participate in the regatta entirely at their own risk. See rule 4, Decision to Race. The Organizing Authority will not accept any liability for material damage or personal injury or death sustained in conjunction with or prior to, during or after the regatta

Jaime Ramón
Principal Race Officer

Brainard Cooper
Class Representative

Rev. 3/19/18

ATTACHMENT "A"

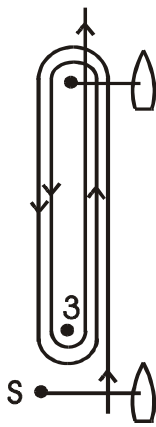

"W"

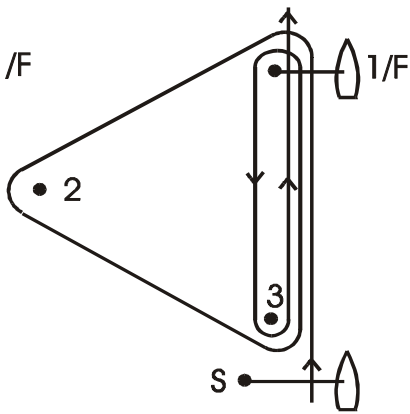

"O"

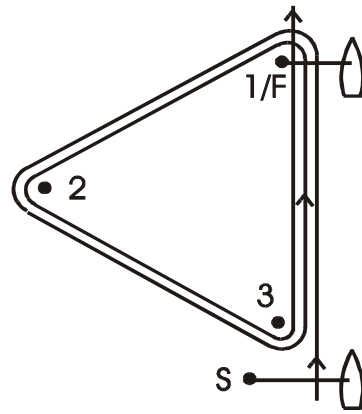

"T"

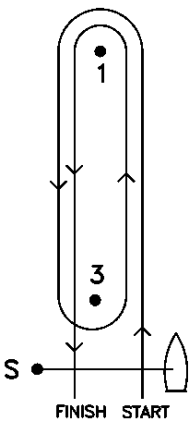

"WD"

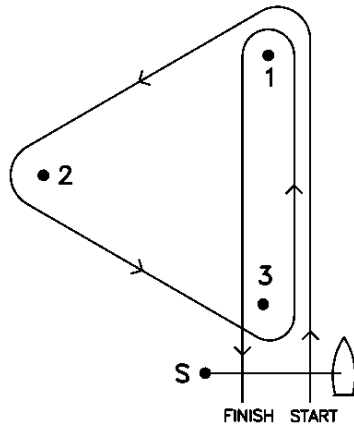
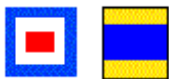

"OD"

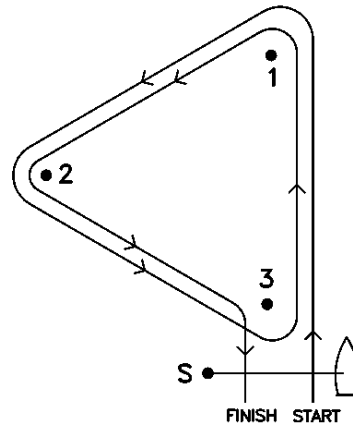

"TD"

