



TROFEO PERPETUO COMODORO MANUEL RASCO
February 1 - 2, 2014
COCONUT GROVE SAILING CLUB
SNIPES FLEET #7
SAILING INSTRUCTIONS



1. RULES:

- 1.1. The race will be governed by the rules as defined in the Racing Rules of Sailing ("RRS"), the current SCIRA Class Rules, By-Laws, and the Rules of Conduct for Conducting National and Local Regattas (ROC), and these sailing instructions.
- 1.2. Racing Rule 63.7 is changed to provide that in the event of a conflict between the Notice of Race and the Sailing Instructions, the Sailing Instructions will prevail.
- 1.3. US National Prescriptions shall apply.
- 1.4. The following Racing Rules are being amended by these Sailing Instructions: RRS 27.1; RRS 30.3; RRS 32; RRS 33; RRS 35; RRS 61; RRS 62.2; RRS 66; RRS Appendix A2; RRS Appendix A4; RRS Appendix A4.2; RRS Appendix A5; RRS Appendix A11; and Race Signals.
- 1.5. The following Rules of Conduct are being amended by these Sailing Instructions: ROC 5, ROC 8.1.
- 1.6. In accordance with the SCIRA Advertising Prescription this event shall comply with ISAF regulation 20.
- 1.7. If there is a conflict between languages the English text will take precedence.

2. NOTICE TO COMPETITORS:

- 2.1. Notices to competitors will be posted on the official regatta notice board located adjacent to the Dockmaster's office of CGSC.

3. CHANGES TO SAILING INSTRUCTIONS:

- 3.1. Any change to the sailing instructions will be posted no later than 90 minutes before the next warning signal, except that any change to the schedule of races will be posted by 1900 hours on the day before it will take effect.
- 3.2. Any change or amendment to the Sailing Instructions shall have the prior approval of the Regatta Chairman or the PRO.

4. SIGNALS MADE ASHORE:

- 4.1. Signals made ashore shall be displayed at the CGSC flag hoist.
- 4.2. When flag AP is displayed ashore, "1 minute" is replaced with "not less than ninety (90) minutes" in the race signal AP. This changes "Race Signals".

5. SCHEDULE OF RACES:

- 5.1. The Race Committee shall attempt to complete as many as 5 races.
- 5.2. Maximum of three (3) races per day.
- 5.3. Warning signal shall be at 1200 hours on Saturday and 1000 hours on Sunday.
- 5.4. No warning signal will be made after 1400 hours on Sunday.

6. CLASS FLAG:

- 6.1. The Class Flag will be a white flag with the Snipe insignia/emblem.

7. RACING AREA:

- 7.1. The Racing Area location is in Biscayne Bay in the vicinity of the entrance to Brennan's Channel.
- 7.2. The distance and direction from the harbor to the racing area is approximately 2 nautical miles in an easterly to south easterly direction.

8. COURSES:

- 8.1. The diagram in Attachment "A" shows the courses, including the approximate angles between legs, the order in which the marks are to be passed, and the side on which each mark is to be left. The course length will be based on sailing conditions. This Changes ROC 5.
- 8.2. No later than one minute before the warning signal, the Race Committee signal boat will display the course to be sailed using code flag "O" for the Olympic course, code flag "T" for the Triangle course, and course flag "W" for the Windward Leeward course with all courses finishing to windward. Courses to be sailed finishing downwind use code flags "OD" for the Gold Cup course, code flags "TD" for the Triangle course, and course flags "WD" for the Windward Leeward course. This changes RRS 27.1.
- 8.3. The course signal flag will be accompanied by one horn signal when raised and will remain displayed for ten minutes after the start. This changes RRS 27.1.

- 8.4. The approximate compass bearing to Mark 1 shall be displayed by a numerical posting on a board on the Race Committee signal boat before the Preparatory signal.
 - 8.5. All marks shall be left to port unless it is a gate or the “start/finish mark” when finishing.
- 9. MARKS:**
- 9.1. Marks 1, 2 and 3 shall be orange tetrahedrons.
 - 9.2. Start/finish mark (Mark S) shall be a yellow tetrahedron.
 - 9.3. New marks as provided in RRS 33 shall be yellow tetrahedrons.
 - 9.4. For the Windward/Leeward course(s) (course “W” or “WD”), an orange ball (yellow when mark 1 has been changed according to RRS 33) will be set as an offset mark approximately four (4) boat lengths adjacent and to port of Mark 1 and a leeward gate will replace Mark 3 (leeward). The two marks forming the gate will be located approximately seven boat lengths apart.
 - 9.5. Mark 3 is not a mark of the course when completing the second lap of courses “WD”, “TD”, or “OD”.
 - 9.6. The Race Committee Signal Boat may set an inflatable buoy attached to its stern. The inflatable buoy and its attachment line are a limit mark and must be left to starboard when starting and when finishing downwind must be left to port.
- 10. THE START:**
- 10.1. The starting line will be between a staff displaying an orange flag or shape on the Race Committee boat at the starboard end and the port-end start/finish mark.
 - 10.2. Boats starting later than ten (10) minutes after their starting signal will be scored Did Not Start (DNS) without a hearing. This changes ROC 8.1, and RRS 35.
 - 10.3. The starting line shall be set approximately 30 meters or 33 yards downwind of Mark 3 (leeward). Mark 3 is not a mark of the course for the first leg of the race.
- 11. CHANGE OF COURSE OR NEXT LEG OF THE COURSE:**
- 11.1. To change the next leg of the course, the Race Committee will lay a new mark (or finish line) and remove the original mark soon as practicable. When in a subsequent change a new mark is replaced, it will be replaced by an original mark.
 - 11.2. Shortening or lengthening the next leg of the course shall not be by more than 30% of the original leg length. This changes RRS 33.
 - 11.3. The number of legs of a Course shall not be reduced until after the second windward leg has been completed. This changes RRS 32.
 - 11.4. Except at a gate, boats shall pass between the Race Committee boat signaling the change of the next leg and the nearby mark leaving the mark to port and the Race Committee boat to starboard.
 - 11.5. When a change of course according to ROC 9.2 is displayed it shall be accompanied by repetitive sound signals.
- 12. THE FINISH:**
- 12.1. For courses “W”, “T”, and “O”, the finish line shall be between a staff displaying an orange flag on a Race Committee boat at the starboard end and Mark “1” at the port-end.
 - 12.2. For courses “WD”, “TD”, and “OD”, the finish line shall be between a staff displaying an orange flag or shape on the Race Committee boat at the port end and the start/finish mark at the starboard end.
 - 12.3. If the Race Committee intends to start another race on the same day, it will display the Second Substitute (with no sound) while boats are finishing. The second substitute will be lowered with one sound signal one minute before the Warning Signal for the next race.
- 13. PENALTIES:**
- 13.1. Any competitor taking a penalty in accordance with RRS 44.1 or 44.2 will notify the Race Committee promptly upon finishing that race and will also inform the Race Committee of the identity of the other boat involved.
 - 13.2. Any boat failing to check-in (CNF), in accordance with 17.1 and 17.2, shall receive a scoring penalty where points will be added to the finishing position equal to 10% of the starters in that race. This changes RRS Appendix A5 and RRS Appendix A11.
 - 13.3. Black Flag shall not be used. This changes RRS 30.3.
 - 13.4. Any boat failing to check in shall be ranked as a starter for scoring purposes only.
 - 13.5. A boat that did not finish shall be scored DNF by the Race Committee without a hearing and shall be scored points equal to one more than the number of finishers. This changes RRS A4.2.
 - 13.6. The penalty for boats found to have broken RRS 55 shall be a 20% percentage penalty for the first race competed in by the infringing boat on the day of the infraction.
- 14. TIME LIMIT:**

- 14.1. In addition to ROC 12 and 12.1, should the first boat fail to complete the first lap within 60 minutes, the Race Committee shall abandon the race. For the purpose of this Rule a lap shall mean the rounding of mark 3 for the first time.
- 14.2. Boats failing to finish within thirty (30) minutes after the first boat sails the course and finishes will be scored a DNF (1 point more than the number of boats finishing within the time limit) without a hearing. This changes RRS Appendix A4, and RRS Appendix A5.
- 15. PROTEST AND REQUEST FOR REDRESS:**
- 15.1. In addition to the requirements in RRS 61, a competitor's intent to protest shall be reported to the Race Committee promptly upon finishing the race in which the incident occurred. This changes RRS 61.
- 15.2. Protest Filing Time shall be within one hour after the Race Committee Finish Boat Docking Time which shall be posted on the official notice board.
- 15.3. Request for Redress Filing Time shall be no later than the Protest time limit or 30 minutes after the incident, whichever is later. This changes RRS 62.2.
- 15.4. Protests shall be made in writing on forms available at the official notice board and filed with the Principal Race Officer (PRO) prior to the expiration of the Protest Filing Time.
- 15.5. Protest notices and hearing schedules specifying the protester and protestee shall be posted no later than one-half hour after the expiration of the protest filing time limit.
- 15.6. On the last scheduled day of racing a request for reopening a hearing shall be delivered:
- a. within the protest time limit if the requesting party was informed of the decision on the previous day.
 - b. no later than 30 minutes after the requesting party was informed of the decision on that day. This changes RRS 66.
- 16. SCORING:**
- 16.1. One race is required to be completed to constitute a series.
- 16.2. A boats series score will be the total of her race scores. No drops. This changes RRS Appendix A2.
- 16.3. A boat that checks in for a race will be ranked as a starter for that race.
- 17. SAFETY REGULATIONS:**
- 17.1. Each day, before the start of a competitors' first race of the day, but not before code flag "L" is displayed by the Race Committee Signal Boat, each boat is required to sail on starboard tack past the stern of the Race Committee Signal boat and verbally check in.
- 17.2. When the Race Committee verbally acknowledges a boat's sail number, the check-in has been officially noted.
- 17.3. A boat that retires from a race shall notify the Race Committee as soon as possible.
- 18. REPLACEMENT OF CREW:**
- 18.1. The same crew shall race in all races, except for reasons satisfactory to the Race Committee.
- 18.2. Requests for the replacement of any member of the crew shall be submitted in writing to the PRO prior to 0900 on the day the change will take effect.
- 18.3. The request for replacement of any member of the crew requires the approval of the PRO or the Race Committee Chair.
- 18.4. Once a skipper and/or crew have been excused, they may not return for the balance of the series.
- 18.5. Co-skippers shall be allowed subject to the restrictions of 18.1 and 18.2.
- 19. EQUIPMENT AND MEASUREMENT CHECKS:**
- 19.1. The Race Committee may inspect competitors or boats not racing at that time. Equipment inspections may be initiated at the finish of any race.
- 20. SUPPORT BOATS:**
- 20.1. No coach, other support or spectator vessels shall be within 100 yards of the racing course except to render assistance. Any competitor associated with personnel determined to have violated this rule shall be subject to protest and assessed a 20% penalty for the race in which the violation occurred.
- 21. PRIZES:**
- 21.1. Prizes shall be awarded to the first three boats of the regular fleet and to the first boat of the AICARDI fleet.
- 21.2. Boats comprising the AICARDI fleet are determined by the Regatta Chairman by the end of the regatta.
- 22. DISCLAIMER OF LIABILITY:**
- 22.1. Competitors participate in the regatta entirely at their own risk. See rule 4, Decision to Race. The Organizing Authority will not accept any liability for material damage or personal injury or death sustained in conjunction with or prior to, during or after the regatta

ATTACHEMENT "A"

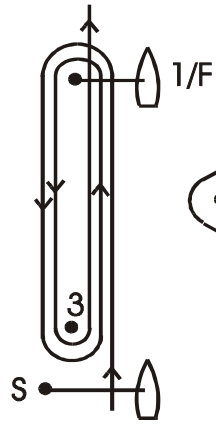

"W"

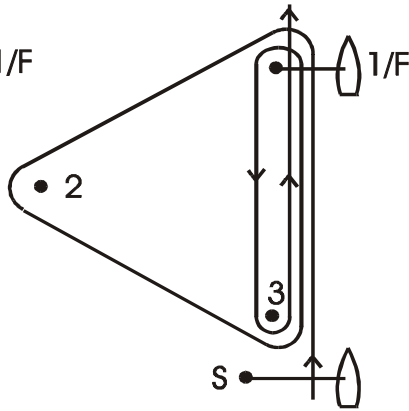

"O"

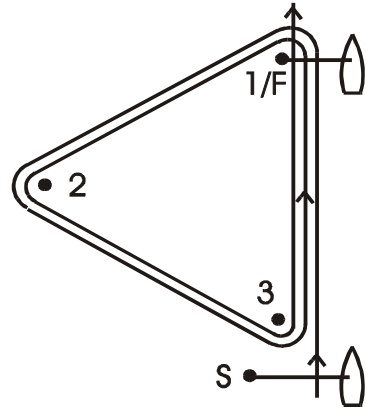

"T"

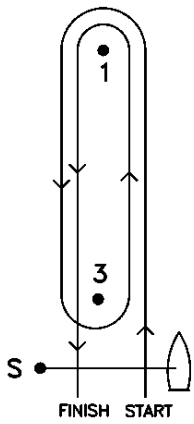

"WD"

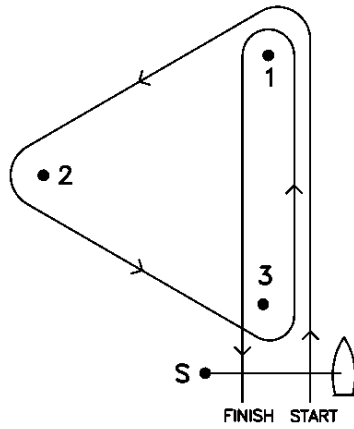

"OD"

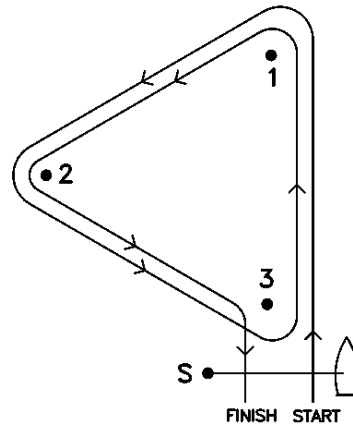

"TD"

