



2017 OPTIMIST SPRING FLING REGATTA

April 8-9, 2017

Hosted by *The Coral Reef Yacht Club*

SAILING INSTRUCTIONS

1. RULES

- 1.1. The regatta will be governed by the rules as defined in *The Racing Rules of Sailing*.
- 1.2. Class rules regarding championships will not apply.
- 1.3. Rule 61 will be changed as follows:
 - (a) The red protest flag required in rule 61.1(a) shall be attached to the sailor's lifejacket in a manner that allows it to be concealed before it is needed and after the protested boat has acknowledged her foul. The last sentence of rule 61.1(a) is deleted; sailors may conceal their protest flag after the incident has ended.
 - (b) Rule 61.1(a)(2) is deleted.
 - (c) The following new rule is added to rule 61:
61.5 Informing the Race Committee (RC)
In addition to meeting the requirements of rule 61.1, a boat intending to protest another boat concerning an incident in the racing area that she is involved in or sees shall, at the first reasonable opportunity after she finishes, notify the finish boat of her intent to protest and the sail number of the boat(s) she is protesting.
- 1.4. SI breaches for which a discretionary penalty may be applied by the Protest Committee (PC) are designated by "[DP]" – Discretionary Penalty.
- 1.5. Rule 63.7 is changed such that if there is a conflict between the Sailing Instructions (SI) and the Notice of Race (NOR), the SI shall govern.

2. FORMAT OF THE CHAMPIONSHIP

- 2.1. *For the Optimist Green Fleet*, all competitors will race in one flight.
- 2.2. *For the Optimist Red, White, and Blue Fleet*:
 - (a) The RWB Fleet *may* be divided into divisions based on the number of entries and will be determined by the RC whose decision will be final and cannot be grounds for a boat to request redress. This changes rule 62.1(a). Division assignments are for the entire regatta
 - (b) In the case of SI 2.2.(a) above, the OA will provide each boat with a colored streamer corresponding to the color of the division to which she is assigned. While on the water, each boat shall at all times display the colored streamer corresponding to her division assignment attached securely to the sprit loop at the top of the sail, and shall not change the size of her streamer.
 - (c) The order of races between divisions are shown in SI Attachment 3.
- 2.3. The Championship Fleet will race in "Sets" of races. For the purposes of the SIs, a "race" is a race between two divisions, and a "Set" is a pair of scored races in which all divisions compete.
- 2.4. If the last race of a "Set" cannot be completed before the end of racing on a given day, that "Set" will be completed first on the succeeding day. On the last day of racing, a boat's score from races in an incomplete "Set" shall not be counted. This changes rule A2.

3. NOTICES TO COMPETITORS

Notices to competitors will be posted on the official notice board located in the breezeway adjacent to the men’s locker room at Coral Reef Yacht Club.

4. CHANGES TO THE SAILING INSTRUCTIONS

Any change to the sailing instructions will be posted on the official notice board before 0900 on the day that it will take effect, except that any change to the schedule of races will be posted by 1900 on the day before it will take effect.

5. SIGNALS MADE ASHORE AND LAUNCHING

- 5.1. Signals made ashore will be displayed on the flagpole located at the Coral Reef Yacht Club (CRYC).
- 5.2. When code flag “AP” is displayed on shore, “1 minute” is replaced with “not less than 45 minutes” in Race Signal “AP.”
- 5.3. Flag G displayed with one sound signal at the CRYC means, “RWB Fleet boats may depart the launching area and proceed directly to the racing area.
- 5.4. Flag K displayed with one sound signal at the CRYC means, “Green Fleet boats may depart the launching area and proceed directly to the racing area.
- 5.5. Boats shall not launch prior to these signals.

6. SCHEDULE OF RACES

Saturday, April 8th	0900	Coaches and parents meeting (mandatory)
	0915	Skippers meeting (mandatory)
	0930	Harbor start for Optimist RWB Fleet
	1000	Harbor Start for Optimist Green Fleet
	1030	First warning of the day for Optimist RWB Fleet
	1100	First warning of the day for Optimist Green Fleet
		<i>Racing to follow lunch on the water</i>
Sunday, April 9th	0830	Harbor start for Optimist RWB Fleet
	0900	Harbor Start for Optimist Green Fleet
	0930	First warning of the day for Optimist RWB Fleet
	1000	First warning of the day for Optimist Green Fleet
		<i>Racing to following Lunch on the water</i>
	1400	No first warning signal after this time

- 6.1. *For the Optimist RWB Fleet*, to alert boats that a race or sequence of races will begin soon, the orange starting line flag will be raised with one sound at least 5 minutes before a warning signal is made.

7. CLASS FLAGS

<i>Class</i>	<i>Flag</i>
Optimist RWB Fleet	Optimist Insignia or Streamer Colors if Applicable
Optimist Green Fleet	Optimist Insignia

8. RACING AREA

The racing areas will be on Biscayne Bay as shown in SI Attachment 1, *Racing Area*.

9. THE COURSE AND CHANGE OF COURSE

- 9.1. SI Attachment 2, *Race Courses*, illustrates the RWB Fleet course, and the Green Fleet course, including the approximate angle between legs, the order in which marks are to be passed, and the side on which each mark is to be left. The course length and exact configuration will be based on sailing conditions.

10. MARKS

- 10.1. *For the Optimist RWB Fleet*, rounding marks 1, 2, and 3 will be orange.
- 10.2. *For the Optimist Green Fleet*, rounding marks will be yellow marks.
- 10.3. New (change) rounding marks will be original marks.

11. THE START

- 11.1. For races following the first race of each day, a series of short sound signals may be made approximately one minute before the starting sequence begins in order to attract attention.
- 11.2. The starting line will be one of the following:

- (a) Between a staff displaying an orange flag on the race committee signal boat and a staff displaying an orange flag on the 'pin' boat.

OR

- (b) Between a staff displaying an orange flag on the race committee signal boat and a mark.

11.3. A boat starting later than 4 minutes after her starting signal will be scored did not start (DNS) without a hearing. This changes Rules 63.1, A4.1 and A5.

11.4. If code flag "I" and/or "Z," code flag "U", or the black flag has been displayed, the race committee may attempt to hail the sail number(s) of boats on the course side of the starting line or its extension during the minute before her starting signal. Failure of the race committee to hail, failure of the amplification system, the order of the hail, or failure of a boat to hear a hail shall not be grounds for a boat to request redress. This instruction changes Rules 41 and 62.1.

12. THE FINISH

12.1. *For the Optimist RWB Fleet,*

- (a) The finish line will be between a staff displaying an orange flag on a race committee boat and a mark. This instruction does not apply when Rule 32.2 is in effect.

- (b) Flag A displayed (with no sound) while boats are finishing means 'No more racing today'.

12.2. *For the Optimist Green Fleet,*

- (a) The finish line will be between a staff displaying an orange flag on a race committee boat and a mark. This instruction does not apply when Rule 32.2 is in effect.

- (b) The race committee will inform competitors verbally after finishing their intent to start another race

13. TIME LIMITS

13.1. The time limit for the first boat in a race to sail the course and finish is ninety (90) minutes.

13.2. Boats failing to finish within twenty (20) minutes after the first boat in a race sails the course and finishes will scored Did Not Finish (DNF) without a hearing. This instruction changes rule 35, A4, and A5.

14. PROTESTS, REQUESTS FOR REDRESS, AND PENALTIES

14.1. In addition to Rule 61 the following applies:

Boats intending to protest an incident occurring in the racing area shall notify a race committee finishing boat immediately after finishing of her intention to protest, and before contacting any support or coach personnel. This changes Rule 61.1(a).

14.2. *For Optimist RWB and Green Fleets,* boats intending to protest must display a red flag and hail protest at the time of the incident. This changes Rule 61.1(a)

14.3. The helmsman shall represent the boat. This changes Rule 63.3(a). Non-English speaking competitors may have an interpreter present during hearings.

14.4. The protest forms are available in the lobby of Coral Reef Yacht Club near the protest notice board. Protests and requests for redress or reopening shall be delivered there within the appropriate time limit.

14.5. The protest time limit is 60 minutes after the race committee finish boat docks and signals with one sound signal. The race committee will post the time for the race committee finish boat docking on the official notice boards as soon as practical after docking.

14.6. The race committee will post a list of boats scored OCS, ZFP, or BFD on the official notice board at the time of the race committee signal boat docking or as soon as practical. A request for redress based on such a posted score shall be made during the protest time limit. This changes the first sentence of Rule 62.2.

14.7. Notices will be posted on the official protest board within 15 minutes of the protest time limit to inform competitors of hearings in which they are parties or named as witnesses. Hearings will be held in a designated room, the location posted on the official protest board. When practicable, hearings may begin before the end of protest time.

14.8. Notices of protest by the race committee or protest committee will be posted on the notice board to inform boats under Rule 61.1(b).

14.9. Scoring inquiries, other than OCS, ZFP, and BFD, shall be completed on Scoring Request forms available from the scoring committee official located in the lobby of the Coral Reef Yacht Club.

14.10. On the last scheduled day of racing a request for reopening a hearing shall be delivered

- (a) Within the protest time limit if the requesting party was informed of the decision on the previous day;

- (b) No later than 30 minutes after the requesting party was informed of the decision on that day. This changes Rule 66.

14.11. On the last scheduled day of racing, a request for redress based on a protest committee decision shall be delivered no later than 30 minutes after the decision was posted. This changes Rule 62.2.

15. SCORING

15.1. The Low Point Scoring System of Appendix A shall apply as revised by these SI.

- 15.2. The number of boats entered in the series will be defined as the number of registered boats which subsequently completed competitor Check-In at the regatta venue. This change rule A4.2.
- 15.3. A "Set" is completed when all divisions have completed a scored race. One completed "Set" shall constitute the regatta.
- 15.4. A boat's scores from races in incomplete "Sets" shall not be counted. This changes rule A2 and 90.3.
- 15.5. Scoring based on races completed:
 - (a) When fewer than five (5) "Sets" of races have been completed, a boat's series score will be the total of all of her race scores.
 - (b) When five (5) or more "Sets" of races have been completed, a boat's series score will be the total of her race scores excluding her worst score.
- 15.6. Based on the 'Division Round Robin' format, rules 44.3(c), and A4.2 are changed so that the scores are based on the combined number of boats registered in the two largest divisions.

16. SAFETY AND CHECK-OUT / CHECK-IN PROCEDURES

- 16.1. Prior to launching each day, each sailor is required to sign out at the Lunch distribution safety table. If a competitor will not be racing that day, he or she shall notify the Land Safety committee. Failure to follow Safety Check-Out procedures will result in the sailor being penalized under SI 1.4.
- 16.2. Immediately upon returning to shore, but not later than 30 minutes after the RC signal boat docks, competitors shall sign in at the safety desk. Failure to follow Safety Check-In procedures will result in the sailor being penalized under SI 1.4.
- 16.3. The Beachmaster is a member of the race committee responsible for safety. Boats not competing in a days racing shall inform the Beachmaster no later than 0930 HRS who will notify the appropriate principal race officer.
- 16.4. Competitors shall wear while on the water, other than for brief periods while adding or removing clothing, a properly secured personal floatation device (PFD). U.S. competitors must wear USCG approved Type III PFDs. Competitors from outside the U.S. must wear a PFD approved by their nations' certification authority or a USCG approved Type III PFD. Y flag will not be displayed. This changes *Race Signals*.
- 16.5. Competitors shall have a whistle attached to their personal flotation device for emergency purposes only.
- 16.6. An adult (parent, guardian or designated adult) is responsible for the safety of the sailor. It is the sole responsibility of the adult to decide if the sailor is to sail in the sea and weather conditions that may arise during the regatta. The adults supervising the competitors are ultimately responsible for the risks.
- 16.7. A boat that retires from a race or leaves the course before racing for the day is completed, shall notify the race committee before leaving the course, or when that is impossible, the receptionist in the lobby of Coral Reef Yacht Club immediately after arrival ashore. Boats failing to do so may be protested by the Beachmaster or race committee, and may result in disqualification from the day's racing.
- 16.8. A boat requiring assistance shall signal by waving an extended arm.

17. EQUIPMENT AND MEASUREMENT

- 17.1. Measurement may be made of boats at anytime during the regatta by the race committee or judges at the direction of the race committee.
- 17.2. Any request to consider approving on the water equipment substitutions shall be submitted to the race committee before the end of that day's protest time limit.

18. COACH AND SUPPORT BOAT REGULATIONS

- 18.1. Team leaders, coaches, other support personnel and spectators must monitor VHF radio channel 72 for RWB course; or channel 69 for the Optimist Green course. The Race Committee may make announcements for information and safety purposes at anytime. The VHF radio channels may be changed at anytime at the discretion of the race committee.
- 18.2. Coaches are expected to be good role models for young sailors and conduct themselves accordingly ashore and on the water. Any behavior that deviates from these expectations may result in restrictions or dismissal from the event at the discretion of the organizing authority, principle race officer, and/or protest committee.
- 18.3. General coach and support boat requirements
 - (a) Coach boats shall fly a Blue flag with a number provided by the race committee at all times while on the water. Coach boats MUST carry a working VHF radio and monitor the race committee channel when possible, particularly in windy or threatening weather.
 - (b) Support boats shall fly a White flag with a number provided by the race committee at all times while on the water.
 - (c) Coach and support boats shall not display distinctive markings or signaling apparatus, or any flags other than their ensign and the flags provided under (a) or (b) above while any boats are racing.

(d) Coach and support boats shall follow the instructions of race committee, safety, protest committee, and race management boats.

(e) No coach or support boat shall tie up to or congregate around any aid to navigation, such as buoys or channel markers.

18.4. Restrictions

(a) All coach and support boats shall stay clear of the racing area (more than 100 yards away from any racing boat) at all times while boats are racing, and move slowly and with minimal wake, except as permitted in this instruction 18.4(b) and 18.4(c) below.

(b) Coaches may anchor only in the areas designated in SI Attachment 2, *Race Courses*, during 'starting' and 'finishing'.

(c) Coach boats may talk to sailors after they finish provided both stay well clear of any racing boat.

18.5. Penalties

(a) Competitors affiliated with any coach or support boat that breaks SI 18 may break Rule 41.

(b) Coaches or support boats that break SI 18 may be subject to disciplinary actions up to and including exclusion from the venue.

18.6. GREEN FLEET COACHING

(a) SI 18.4 does not apply for the Green Fleet. Coaching of the Green Fleet skippers while racing is permitted; however, coaching shall be limited to the bottom half of the fleet in any race. Coach boats shall neither create wakes nor otherwise interfere with competitors. Violations of this instruction may result in any penalty that the protest committee deems appropriate.

19. PRIZES

Prizes will be awarded according to the notice of race. Subsequent prizes may be awarded at the discretion of the organizing authority.

20. DISCLAIMER OF LIABILITY

Competitors participate in the regatta entirely at their own risk. See Rule 4, Decision to Race. The organizing authority will not accept any liability for material damage or personal injury or death sustained in conjunction with or prior to, during, or after the regatta. A waiver must be signed by all competitors and their parent/guardian.

2017 SPRING FLING REGATTA

ATTACHMENT 1

RACING AREA

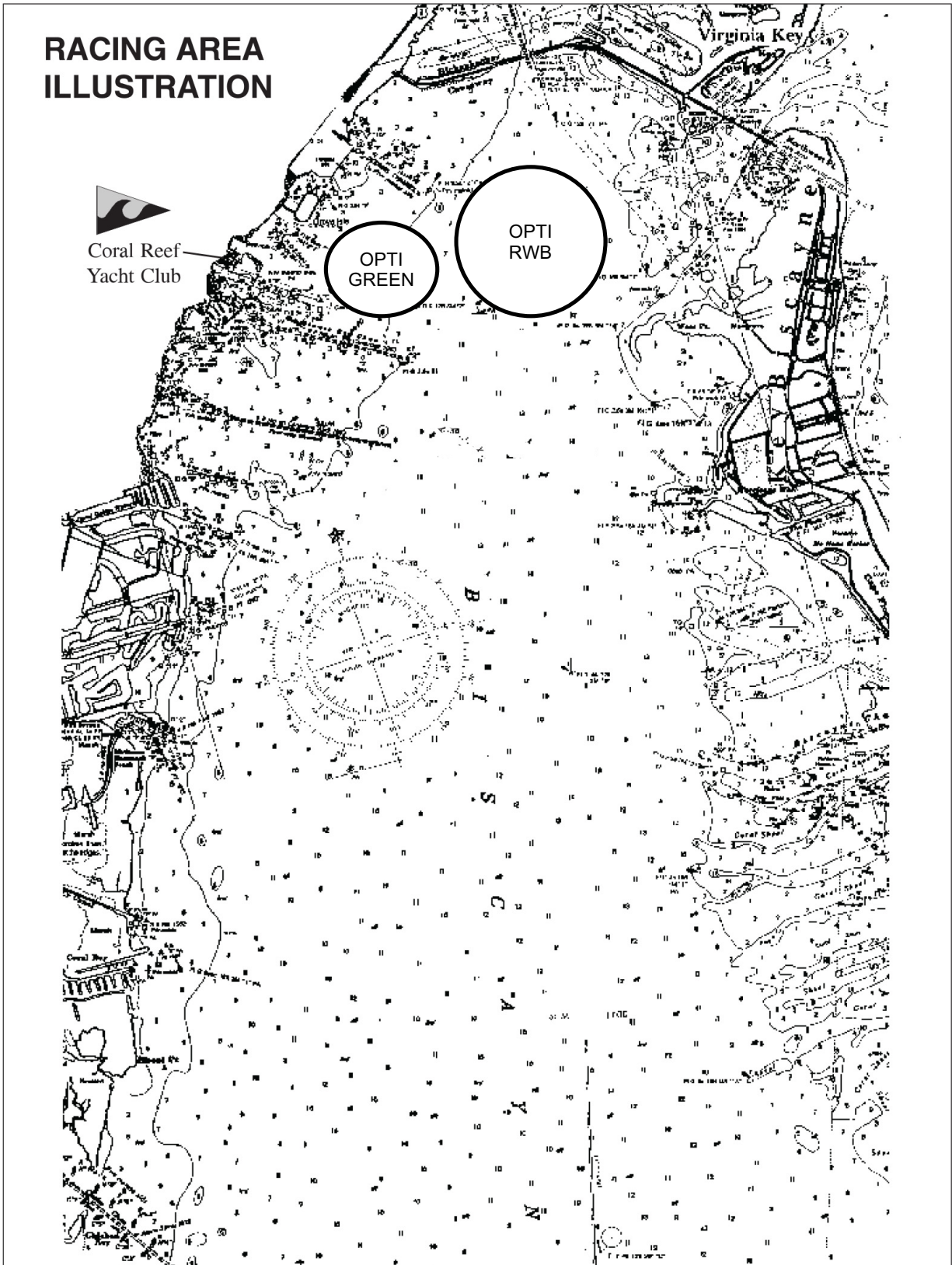

2017 SPRING FLING REGATTA

ATTACHMENT 2

OPTIMIST RWB FLEET COURSE

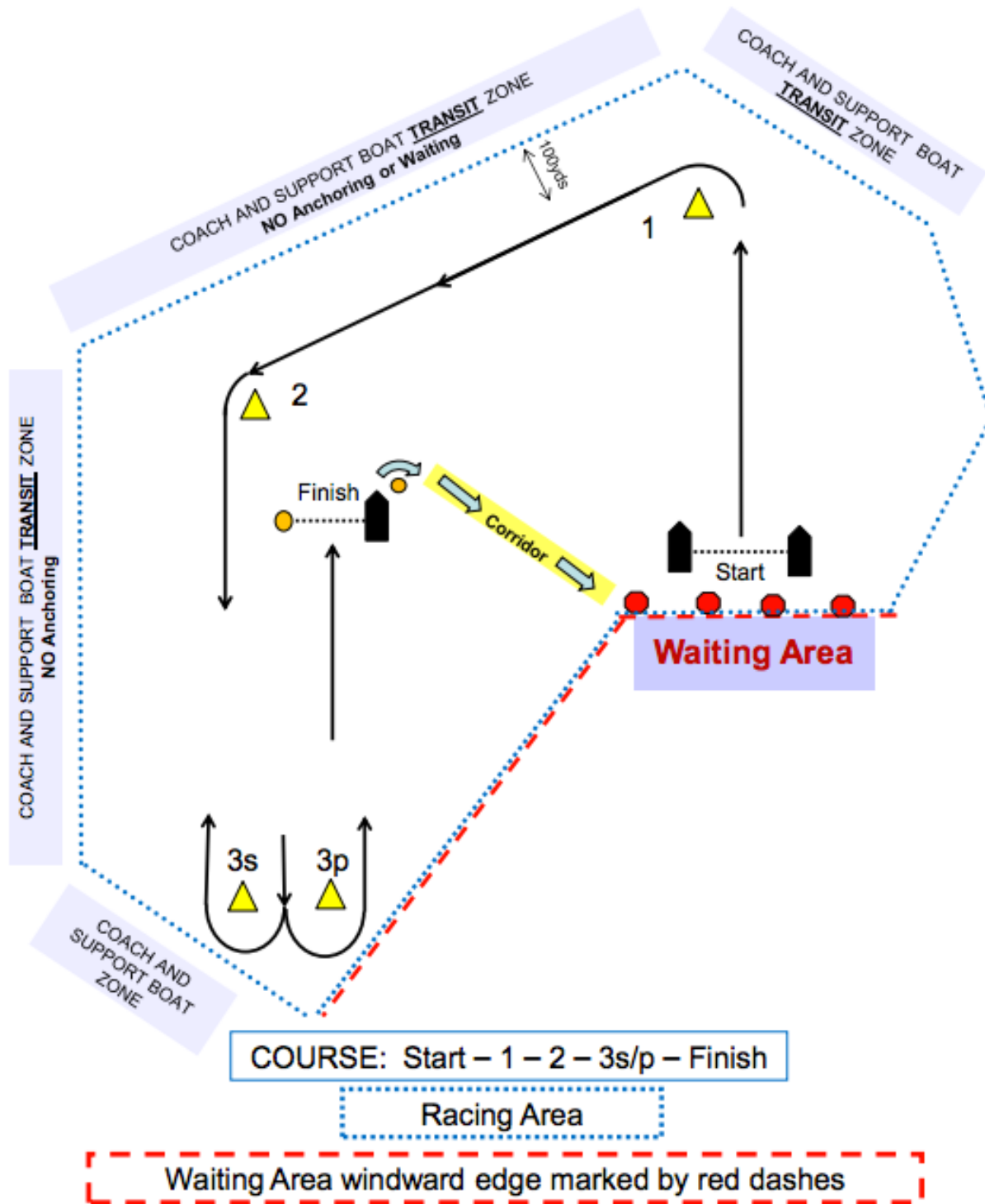

Important note: Mark colors and shapes are illustrative only.

2017 SPRING FLING REGATTA

ATTACHMENT 2

OPTIMIST GREEN FLEET COURSES

Course Designation

T

Start -1- 2- 3 - Finish

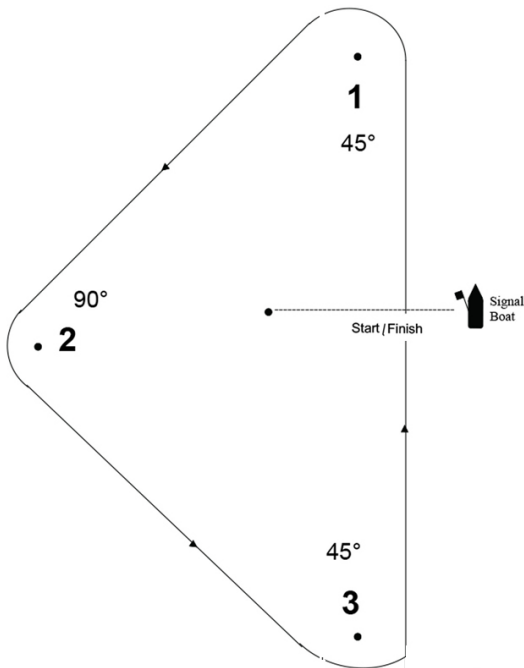

Course Designation

O

Start -1- 2- 3 -1- Finish

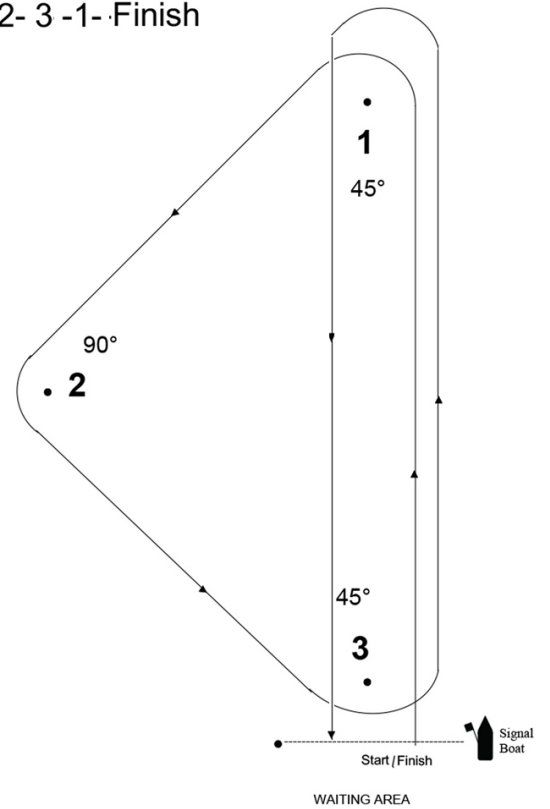

2017 SPRING FLING REGATTA
ATTACHMENT 3
OPTIMIST RWB FLEET SCHEDULE OF RACES

SET ONE

Start (1a)	PINK DIVISION	and	BLUE DIVISION
Start (1b)	PURPLE DIVISION	and	YELLOW DIVISION

SET TWO

Start (2a)	PINK DIVISION	and	PURPLE DIVISION
Start (2b)	BLUE DIVISION	and	YELLOW DIVISION

SET THREE

Start (3a)	BLUE DIVISION	and	PURPLE DIVISION
Start (3b)	YELLOW DIVISION	and	PINK DIVISION

SET FOUR

Start (4a)	PURPLE DIVISION	and	YELLOW DIVISION
Start (4b)	PINK DIVISION	and	BLUE DIVISION

SET FIVE

Start (5a)	BLUE DIVISION	and	YELLOW DIVISION
Start (5b)	PINK DIVISION	and	PURPLE DIVISION

SET SIX

Start (6a)	YELLOW DIVISION	and	PINK DIVISION
Start (6b)	BLUE DIVISION	and	PURPLE DIVISION

***ADDITIONAL SETS CONTINUE FROM SET ONE.

Once six sets are completed, the 7th set re-cycles as set one, the 8th set as set two, and so on.