



Harbor 20 East-West Challenge September 8-10, 2017

Organizing Authority: Annapolis Yacht Club
Annapolis, Maryland, USA

Event Website: <http://www.annapolisyc.com/racing/regattas>

AMENDMENT #1 to the SAILING INSTRUCTIONS

The first sentence of SI 10.1, Marks, is replaced with:

The start/finish mark and mark 1a will be yellow cylinders.

SI 14, Finish, is replaced with:

The finishing line will be between a staff or halyard displaying an orange flag on the race committee finishing vessel and the course side of the finishing mark.

SI ATTACHMENT 1, A1 is replaced with:

A1 ASSIGNING BOATS

A1.1 At the Friday Welcoming Party:

- (a) Boats will be assigned by random draw: The East and West team captains will alternate drawing boat numbers until 8 boats have been drawn for each team.
- (b) The boat draw will determine the boats assigned to each team on Saturday.
- (c) Skippers will not swap boats during the day.

A1.2 Saturday Assignments

- (a) The team captain will assign boats to the skippers on their team and inform the race committee of the assignments by the start of the Saturday morning briefing.
- (b) The race committee will distribute the boat assignments to the teams before leaving the harbor for racing.

A1.3 Sunday Assignments

- (a) For Sunday, the teams will swap boats so that the 8 boats sailed by East Team on Saturday will be sailed by the West Team on Sunday.
- (b) The team captain will assign boats to the skippers on their team and inform the race committee of the assignments by the start of the Sunday morning briefing.
- (c) The race committee will distribute the boat assignments to the teams before leaving the harbor for racing.

SI Attachment 2, Courses, is replaced with (see next page)

SI ATTACHMENT 2 - COURSES

In the below table, the course designation is followed by the mark rounding order for that course. All marks except 2S are to be rounded to port. If the race committee displays "NO GATE" near the course designation, then mark 2S will not be set. If there is a conflict between the color or shape of a mark below and SI 10, SI 10 will govern.

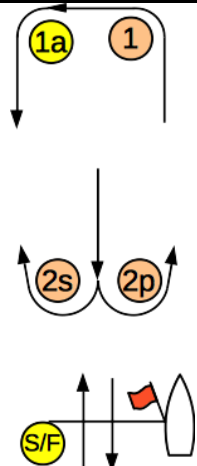
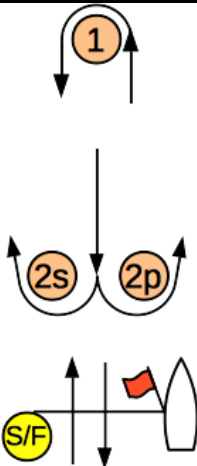
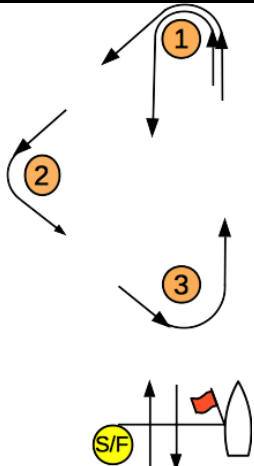
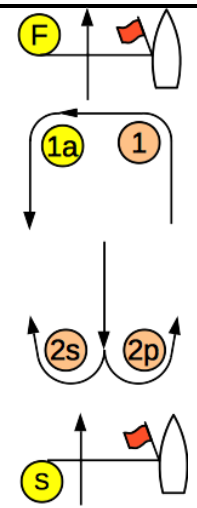
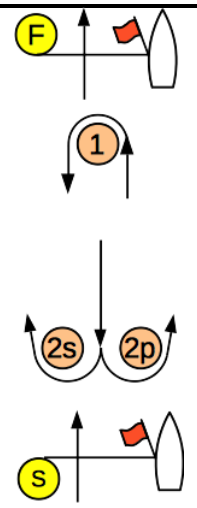
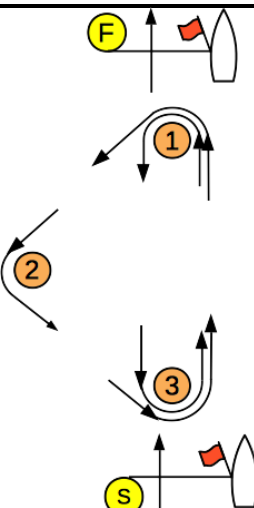
<div style="font-size: 2em; font-weight: bold; margin-bottom: 10px;">LA</div>  <p>LA2: Start-1-1a-2s/2p-1-1a-Finish LA3: Start-1-1a-2s/2p-1-1a-2s/2p-1-1a-Finish</p>	<div style="font-size: 2em; font-weight: bold; margin-bottom: 10px;">L</div>  <p>L2: Start-1-2s/2p-1-Finish L3: Start-1-2s/2p-1-2s/2p-1-Finish</p>	<div style="font-size: 2em; font-weight: bold; margin-bottom: 10px;">TL</div>  <p>TL2: Start-1-2-3-1-Finish TL3: Start-1-2-3-1-3-1-Finish</p>
<div style="font-size: 2em; font-weight: bold; margin-bottom: 10px;">WA</div>  <p>WA2: Start-1-1a-2s/2p-Finish WA3: Start-1-1a-2s/2p-1-1a-2s/2p-Finish WA4: Start-1-1a-2s/2p-1-1a-2s/2p-1-1a-2s/2p-Finish</p>	<div style="font-size: 2em; font-weight: bold; margin-bottom: 10px;">W</div>  <p>W2: Start-1-2s/2p-Finish W3: Start-1-2s/2p-1-2s/2p-Finish W4: Start-1-2s/2p-1-2s/2p-1-2s/2p-Finish</p>	<div style="font-size: 2em; font-weight: bold; margin-bottom: 10px;">TW</div>  <p>TW2: Start-1-2-3-Finish TW3: Start-1-2-3-1-3-Finish</p>

