

SAILING INSTRUCTIONS

SNIFE CLASS INTERNATIONAL RACING ASSOCIATION

2018 EUROPEAN CHAMPIONSHIP
European Championship Trophy
20.-25.08.2018
Segelföreningen i Björneborg r.f. (BSF)
Pori, Finland

Notation [NP]

The notation [NP] in a rule in the SI means that a breach of this rule shall not be grounds for a protest by a boat.

Notation [SP]

The notation [SP] in a rule in the SI means that for a breach of this rule a standard penalty will be applied.

1 RULES

1.1 The regatta will be governed by the rules as defined in *The Racing Rules of Sailing*.

1.2 No National prescriptions will apply.

1.3 The Rules of Conduct for Conducting National and International Championship and the trophy restrictions of the deed of gift of the European Championship Trophy will apply. Any conflict arising between the Deed of Gift and the SCIRA Rules of Conduct shall be solved by the application of the Rules of Conduct.

1.4 In case of conflict between the Notice of Race and the Sailing Instructions the Sailing Instructions shall prevail.

1.5 If there is a conflict between languages the English text will take precedence.

2 NOTICES TO COMPETITORS

Notices to competitors will be posted on the official notice board located at the wall of the Race Office.

3 CHANGES TO SAILING INSTRUCTIONS

3.1 Any change to the sailing instructions will be posted before 09:00 am on the day it will take effect, except that any changes to the schedule of races will be posted by 08:00 pm on the day before it will take effect.

3.2 Any change or amendment to the Sailing Instructions will be approved with the SCIRA Representative.

4 SIGNALS MADE ASHORE

4.1 Signals made ashore will be displayed near the Race Office.

4.2 When flag AP is displayed ashore, '1 minute' is replaced with 'not less than 60 minutes' in the race signal AP.

5 SCHEDULE OF RACES

5.1 Dates of racing:

Date	Earliest Time of Warning Signal	
22.08.2018	11:00	First race of the day
23.08.2018	11:00	First race of the day
24.08.2018	11:00	First race of the day
25.08.2018	11:00	First race of the day

5.2 11 races are scheduled.

5.3 No more than three (3) races will be sailed per day.

5.4 To alert boats that a race or sequence of races will begin soon, an orange flag will be displayed with one sound signal at least four minutes before a warning signal is made.

5.5 On the last day of racing no warning signal will be made after 03:00 pm.

5.6 There may be a competitors meeting at 08:30 am on Wednesday the 22nd of August near the Race Office and announced by two sound signals.

6 CLASS FLAGS

The official Class Flag will be the Snipe Class flag, a red Snipe on a white background.

7 RACING AREAS

Attachment A shows the location of the racing area.

8 WEATHER LIMITATION (Course and Starting)

8.1 The wind speed ranges shall be no less than 5 knots and not exceed 23 knots or in accordance with the applicable Deed of Gift.

9 THE COURSES

9.1 The diagrams below show the courses, including the approximate angles between legs, the order in which marks are to be passed. All course marks (except gates) shall be left to port.

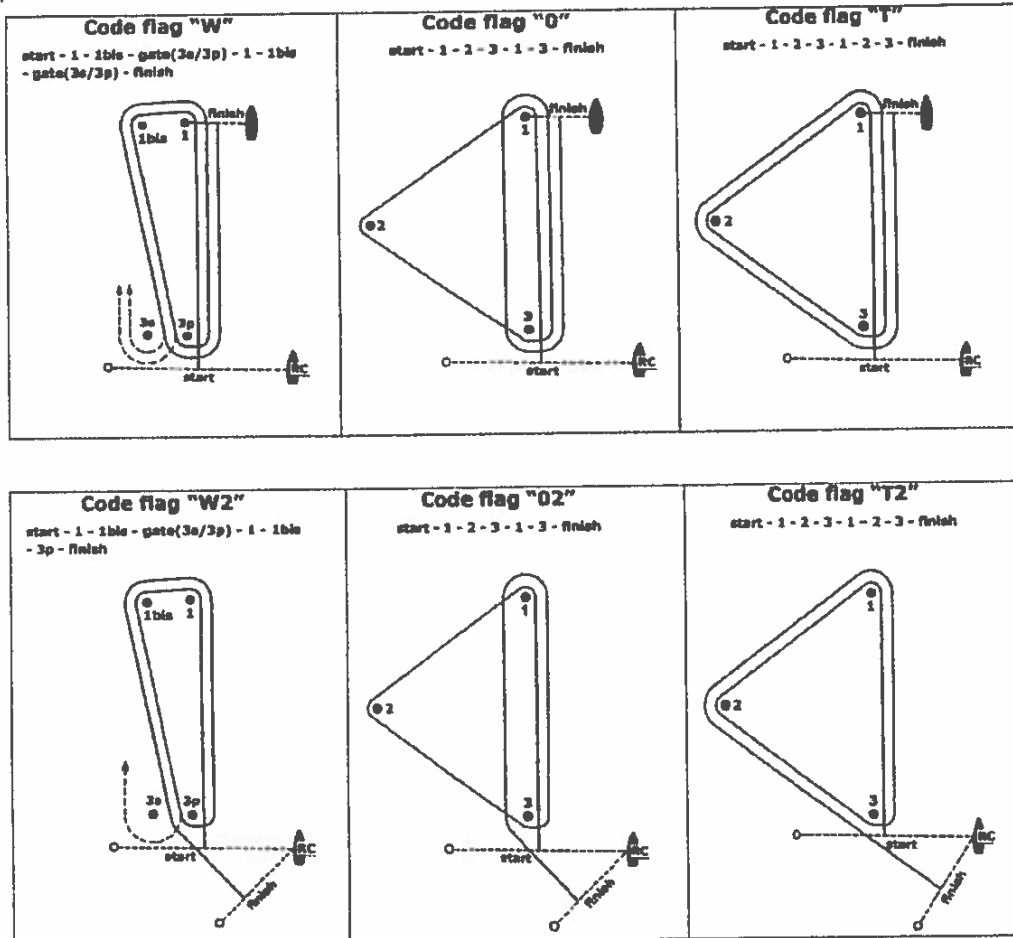

9.2 The course signal (code flag "W", "T", "O", "W2", "T2" or "O2") will be displayed one minute before the warning signal and accompanied by one sound signal. It will remain displayed for ten minutes after the start.

9.3 No later than the warning signal, the Race Committee signal boat will display the approximate compass bearing of the first leg.

9.4 If during a race the wind and/or wave action changes to the point where the selected course would be inadvisable (See Course Selection Diagram), the Race Committee will change the course at any mark. A change of the type of course during the race will be signalled displaying the new appropriate flag and accompanied by repetitive sounds before the leading boat has passed or rounded the mark.

9.5 The number of legs in a race may be reduced (RRS code flag S) but at least 2 (two) windward legs of the race shall be completed. This changes RRS 32.2. [*The SCIRA Representative will be consulted.*]

9.6 A sustained wind variation of 20 degrees or more from the posted bearing during the first leg of a race will result in the race to be abandoned and re-sailed, or abandoned. This changes RRS 32.1.

9.7 A sustained wind variation of 40 degrees or more of the posted bearing during the first lap will result in the race being abandoned and re-sailed, or abandoned. For the purpose of this rule a lap means the rounding of mark 3 (or passing the gate 3s-3p) for the first time. This changes RRS 32.1.

10 MARKS

10.1 Marks 1, 1bis, 2, 3, 3s and 3p will be red inflatable marks.

10.2 New marks, as provided in instruction 13.1, will be red inflatable marks.

10.3 The starting marks will be a Race Committee vessel displaying an orange flag on its mast on the starboard end and a red flag on a buoy at the port end.

- 10.4 The finishing marks will be a Race Committee vessel displaying an orange flag, and a buoy with a red flag or the course mark number 1 depending on the course type.
- 10.5 A Race Committee vessel signalling a change of a leg of the course is a mark as provided in SI 13.2.
- 10.6 If one of the marks "gate 3s-3p" is not placed, or is not replaced as per RRS 34, the remaining mark shall be left to port.
- .
- 11 AREAS THAT ARE OBSTRUCTIONS
There are no areas designated as obstructions.
- 12 THE START
- 12.1 Races will be started by using RRS 26.
- 12.2 The starting line will be between an orange flag or shape on the Race Committee vessel at the starboard end and the course side of the port end starting mark.
- 12.3 A boat starting later than 5 minutes after her starting signal will be scored Did Not Start without a hearing. This changes Appendices A4 and A5.
- 12.4 RRS 30.4 ('Black Flag Rule') will not be used.
- 12.5 The Race Committee, after the finish of a race and before the warning signal of a subsequent one, will do its best to post on the Race Committee vessel a list of OCS and/or ZFP and/or UFD boats. The failure of posting or an incomplete or wrong list will not be grounds for redress. This changes RRS 62.1(a).
- 13 CHANGE OF THE NEXT LEG OF THE COURSE
- 13.1 Changes to the next leg of the course shall be made using RRS 33. To change the next leg of the course, the Race Committee will lay a new mark (or move the finishing line) and remove the original mark as soon as practicable. When in a subsequent change a new mark is replaced, it will be replaced by an original mark.
- 13.2 Except at a gate, boats shall pass between the race committee boat signalling the change of the next leg and the nearby mark, leaving the mark to port and the race committee boat to starboard. This changes RRS 28.1.
- 13.3 After the completion of first windward leg of the race the remaining legs may be increased or decreased (RRS 33 +/-) by not more than 30% of the original length. This changes RRS 33). [*The SCIRA Representative will be consulted on any change of course which affects its length.*]
- 13.4 If Mark 1 is changed in courses "W" or "W2", Mark 1bis (offset) will no longer be a mark.
- 14 THE FINISH
- 14.1 The finish line will be between an orange flag or shape on a Race Committee vessel and the course side of the other finishing mark.
- 15 PENALTY SYSTEM
- 15.1 Appendix P will apply.
- 16 TIME LIMITS AND TARGET TIMES
- 16.1 The races will be managed to last 60-75 minutes for the first boat to finish. A different time (shorter or longer) used to complete the race will not be ground for requesting redress.
- 16.2 The time limit for the first boat to complete the first lap is 40 minutes from the start. If the first boat fails to complete the first lap within 40 minutes the Race Committee will abandon the race. For the purpose of this rule a lap means the rounding of Mark 3 (or passing the Gate 3s/3p) for the first time.
- 16.3 The time limit for the first boat to finish the race will be 1 hour, 30 minutes. Any boat finishing more than 30 minutes after the first boat finishes or failing to finish within 2 hours from the start, whichever is shorter, will be scored Did Not Finish (DNF). This changes RRS 35, A4 and A5.
- 17 PROTESTS AND REQUESTS FOR REDRESS
- 17.1 Protest forms are available at the Race Office, located near the boat park. Protests and requests for redress or reopening shall be delivered there within the appropriate time limit.
- 17.2 The protest time limit is 90 minutes after the last boat has finished the last race of the day or the Race Committee signals no more racing today, whichever is later.
- 17.3 Notices will be posted no later than 30 minutes after the protest time limit to inform competitors of hearings in which they are parties or named as witnesses. Hearings will be held in the protest room, located at the Yyteri Beach Hotel, beginning at the time posted.
- 17.4 Notices of protests by the Race Committee, Technical Committee or the International Jury will be posted to inform boats under RRS 61.1(b).
- 17.5 A list of boats that have been penalized for breaking RRS 42 or RRS 29 and 30 will be posted on the Official Notice Board.
- 17.6 Breaches of rules in the SI marked with [NP] and NoR 3.4 (bow numbers) will not be grounds for a protest by a boat. This changes RRS 60.1(a).
The penalty for breaking rules in the SI marked with [SP] and NoR 3.4 (bow numbers) shall be the 5% scoring penalty for nearest race completed by the infringing boat but not worse than the number of points corresponding to DSQ. Penalties for breaking Class Rules may be less than disqualification.

- 17.7 On the last scheduled day of racing a request for redress based on a decision of the International Jury shall be delivered no later than 30 minutes after the decision was posted. This changes RRS 62.2.
- 17.8 An International Jury is constituted and shall have authority per RRS Appendix N. Their decision shall be final as provided in RRS 70.5. Per Appendix N2.2, SCIRA reserves for itself the right and responsibility to decide issues of eligibility, measurement and equipment. SCIRA may refer any issue to the International Jury for advice.
- 17.9 The use of team racing tactics will not be tolerated.
- 17.10 For the purpose of RRS 64.3(b) the "authority responsible" is the Measurer of the event.
- 17.11 The International Jury will abandon the race if, during a redress hearing, they conclude that the Race Committee did not follow Sailing Instructions 8.1, 9.5, 9.6, 9.7, and 13.3. This changes RRS 64.2.

18 SCORING

- 18.1 Three (3) races are required to be completed to constitute a series.
- 18.2 (a) When fewer than six (6) races have been completed, a boat's series score will be the total of her race scores.
 (b) When from six (6) to eight (8) races have been completed, a boat's series score will be the total of her race scores excluding her worst score.
 (c) When nine (9) or more races have been completed, a boat's series score will be the total of her race scores excluding her two worst scores.
- 18.3 A boat intending to retire and be scored RET shall report its intent in writing to the Jury.

19 [NP][SP] SAFETY REGULATIONS

- 19.1 Check-Out and Check-In: All participating skippers must every day sign out before going a float and when coming back ashore sign in inside the official protest time at the Race Office. When failing to do so this will lead to a penalty in accordance with SI 17.6.
- 19.2 A boat that retires from a race shall notify the race committee as soon as possible.

20 REPLACEMENT OF CREW OR EQUIPMENT

- 20.1 The same crew shall race in all races, except for reasons satisfactory to the Race Committee. Requests for a change of crew shall be submitted in writing to the Chairman. Once a crew has been excused, he/she may not return for the balance of the series.
- 20.2 The same skipper shall sail all races and can be replaced after the first race only, and then only if he/she is obviously incapacitated. If a skipper is replaced the first race shall be the race excluded, or scored DNC.
- 20.3 [NP] Substitution of damaged or lost equipment will not be allowed unless authorized by the Race Committee. Requests for substitution shall be made to the Race Committee at the first reasonable opportunity.

21 [NP] EQUIPMENT AND MEASUREMENT CHECKS

A boat or equipment may be inspected at any time for compliance with the Class Rules and Sailing Instructions. On the water, a boat can be instructed by a Technical Committee equipment inspector or measurer to proceed immediately to a designated area for inspection.

22 [NP][SP] EVENT ADVERTISING

Boats shall display event advertising supplied by the organizing authority as follows: Event advertising will be supplied by the organizing authority together with the bow numbers.

23 RIGHTS TO USE NAME AND LIKENESS

By participating in this event, competitors automatically grant to the SCIRA, organizing authority and the event sponsors the right, in perpetuity, to make, use, and show, at their discretion, any photography, audio and video recording, and other reproductions of them made at the venue or on the water from the time of their arrival at the venue, until their final departure, without compensation.

24 OFFICIAL BOATS

Official boats will be marked as follows:

Race Committee: White flag with number "1", "2", "3" or "4"

Technical Committee: White flag with number "3"

Jury: Signal flag letter "J"

Media: White flag with "MEDIA"

Rescue boats: White flag with number "10", "11" or "12"

The Rescue Boat with medical support also displays a signal flag letter "R".

- 25 [NP] SUPPORT BOATS
- 25.1 At the preparatory signal, coaches must be positioned at least 50 meters below the starting line. After the starting signal coaches may follow the fleet, but only on the port side of the course and must stay 50 meters from any mark and from any boat racing.
- 25.2 Coaches may not communicate with competitors after the warning signal for any race until after the competitors have finished the race. This changes the preamble to RRS Part 4.
- 25.3 Coaches shall register at the Regatta Office and all support boats shall be identified with a blue flag having a letter.
- 26 RADIO COMMUNICATIONS
- A boat shall neither make or receive radio transmissions while racing nor receive radio communications not available to all boats, except in an emergency or when using equipment provided by the race committee. This restriction also applies to mobile telephones.
- 27 TRASH DISPOSAL
- Trash may be placed aboard support and Committee Vessels.
- 28 PRIZES
- Prizes will be awarded as provided by NoR.
- 29 DISCLAIMER OF LIABILITY
- Competitors participate in the regatta entirely at their own risk. See RRS 4, Decision to Race. The organizing authority will not accept any liability for material damage or personal injury or death sustained in conjunction with or prior to, during, or after the regatta.
- 30 INSURANCE
- Each participating boat shall be insured with valid third-party liability insurance with a minimum cover of 500 000 € for personal and 250 000 € for material damages per incident or the equivalent.

Signatures:



Ben Karlemo - Race Committee Chairman



Jerilyn Biehl - SCIRA Representative

