



TRED AVON YACHT CLUB
PENGUIN & COMET FROSTBITE – November 3rd, 2018



SAILING INSTRUCTIONS

PRO: Bob Greenlee

RULES

This regatta will be governed by the Racing Rules of Sailing and these Sailing Instructions.

NOTICES TO COMPETITORS

Notices and changes to Sailing Instructions will be posted on the official bulletin board located in the club house.

CHANGES TO SAILING INSTRUCTIONS

Any change to the sailing instructions will be posted before 0945 on Saturday, November 3rd, 2018.

Skippers Meeting will be held at 0945 in the clubhouse.

SIGNALS MADE ASHORE

Signals made ashore will be displayed from the upper deck of the TAYC clubhouse. When flag AP is displayed ashore, "1 minute" is replaced with "not less than 45 minutes" in the race signal AP.

SCHEDULE OF RACES

The regatta will consist of as many races as possible with no race starting after 1430.

First Warning is scheduled for 1045

COURSES

The diagrams in Attachment "*Course Diagrams*" show the courses, including approximate angles between legs, the order in which marks are to be passed and the side on which each mark is to be left. No later than the warning signal, the race committee signal boat will display the course letter and the approximate compass bearing and distance to the first mark. In addition, for Course "M" or "W", the number of laps to be sailed will be displayed.

FOR COURSES "M" OR "W" BOATS MAY NOT SAIL THRU THE START/FINISH LINE UNLESS STARTING OR FINISHING.

The course can be changed or shortened at any mark of the course.

MARKS

The starting/finishing mark will be an orange ball. Windward, leeward and wing marks will be orange balls.

START

Class starting order and signals are:

Comet	Comet class flag
Penguin	Penguin class flag

Races will start using RRS 26.

The Race Committee will sound a "Heads Up" signal shortly before the Warning sound for each class.

The warning signal for each succeeding class will be made after the starting signal of the previous class.

The starting line will be between a staff displaying an orange flag on the signal boat and the nearby orange starting/finishing mark.

CHANGE OF THE NEXT LEG OF THE COURSE

To change the next leg of the course, the race committee will move the original mark or finishing line to a new position.

FINISH

The finishing line will be between a staff displaying an orange flag on the signal boat and the starting/finishing mark.

TIME LIMITS

One (1) hour for each class, with a finish time limit of 15 minutes after the first boat in each class finishes. Any boat finishing after the time limit will be scored TLE and given 2 points plus the last properly finishing boat, not to exceed class registrants plus one. This changes Rule A5.

PROTESTS

A yacht desiring to protest must notify the other contestants involved. The protesting yacht shall notify the race committee boat at the finish line and receive acknowledgment. A written protest must be filed with the Race Committee within one hour after the committee boat returns to the dock. Time and location of protest meetings will be posted on the official bulletin board.

SCORING

The Low Point Scoring System, Appendix A will apply. One race shall be completed to constitute a series. If 5 or more races are completed each boat's series score, subject to 90.3(b), be the total of her race scores excluding her worst score. This changes

PRIZES

Course Diagrams

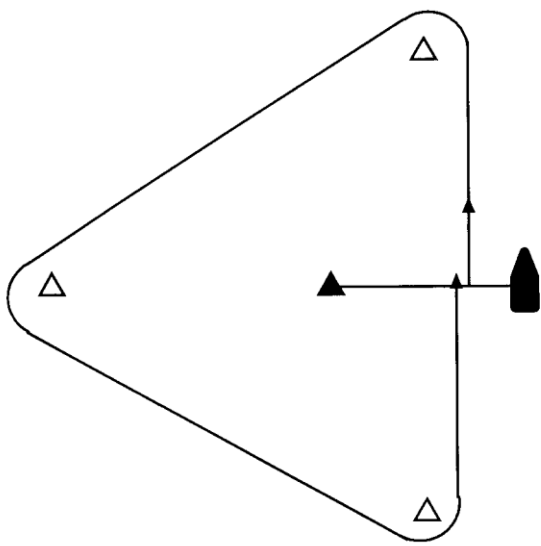

Course M

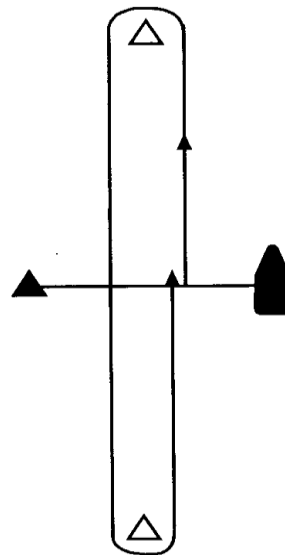

Course W

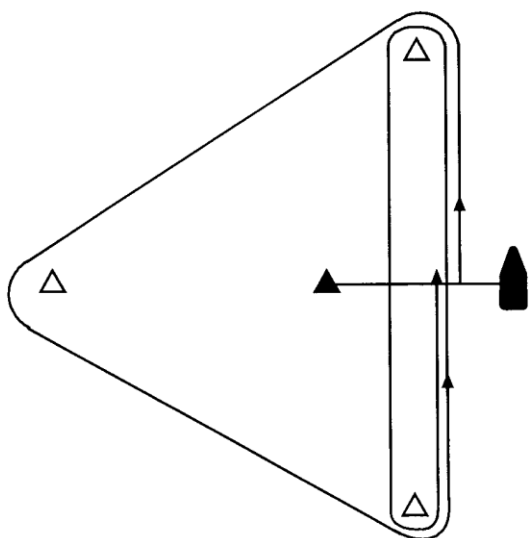

Course O