



2018 Maryland State Championship

RHYC Junior One-Design Regatta

June 28-29, 2018

Rock Hall Yacht Club, Rock Hall, MD 21661

SAILING INSTRUCTIONS

1. RULES

The regatta will be governed by rules as defined by the Racing Rules of Sailing (RRS), the rules of the International Optimist, International Laser, Laser Radial, and Club 420 classes except as any of these are changed by these sailing instructions.

2. ENTRIES

Boats that have completed registration are eligible to race.

3. SAFETY

- 3.1 Competitors must wear a fully secured Coast Guard-approved Type III PFD at all times while afloat, except for brief periods while adding or removing clothing. Whistles permanently attached to the PFDs are recommended. Floatation aids (ZhiK, Baltic) are not permitted to be worn by competitors.
- 3.2 Coaches shall wear USCG approved Personal Flotation Devices (PFDs) at all times while afloat, except for brief periods while changing.
- 3.3 Failure to comply with 3.1 will be grounds for disqualification from all races sailed in violation of those instructions.
- 3.4 In the case of a coach not complying with 3.2, all sailors associated with his / her club may be subject to a penalty imposed by the protest committee, up to and including disqualification from all races sailed.
- 3.5 Protests can only be filed by race committee or on the water judges.
- 3.6 Competitors and/or coaches shall supply the equipment to meet the requirements of 3.1 and 3.2.
- 3.7 A boat retiring from a race shall notify a race committee boat before leaving the course, or, when that is impossible, the Regatta Office immediately after arrival ashore.
- 3.8 A boat shall carry all equipment required by her class rules.

4. CHECK-IN

- 4.1 All competitors must register online or onsite and check-in onsite prior to racing.
- 4.2 All competitors must confirm their sail number to the registration desk upon check-in on site.
- 4.3 Competitors must check in with the race committee signal boat on the water before the warning signal of the first race on each day of competition.

5. NOTICES TO COMPETITORS

Notices to competitors will be posted on the Official Sailing Bulletin Board in the RHYC Lounge.

6. CHANGES IN SAILING INSTRUCTIONS

- 6.1 Any change to the sailing instructions will be announced at the skipper's meeting and posted within 15 minutes of the conclusion of the skipper's meeting. All changes to the sailing instructions will be posted in writing on the Official Sailing Bulletin Board in the RHYC Clubhouse.
- 6.2 Oral changes to the sailing instructions may be given on the water as permitted in RRS 90.2 (c) prior to giving such instructions. The signal boat shall display flag L to ask the competitors to "Come within hail". Failure to hear such oral instructions shall not be grounds for redress.

7. SIGNALS MADE ASHORE

- 7.1 Signals made ashore will be displayed on the fixed flag pole on the end of the pier.
- 7.2 Flag AP displayed ashore with two sounds (one sound when lowered) means, "Racing is postponed. The competitors should stay ashore. The warning signal will be made not less than 30 minutes after AP is lowered ashore." This changes Race Signals AP.



2018 Maryland State Championship

RHYC Junior One-Design Regatta

June 28-29, 2018

Rock Hall Yacht Club, Rock Hall, MD 21661

8. SPECIAL SIGNALS

The display of Flag "H" (white and red vertical bars) at the finish of any race means, "Racing has ended for the day."

9. CLASS FLAGS

The class flags will be displayed at the Skippers Meeting.

10. RACING AREA

The racing area will be as shown in Illustration A, attached; there will be three courses as depicted. The Optimist Green Fleet course (Alpha) will be closest to the club beach in Langford Creek. The Optimist White, Blue and Red course (Bravo) will be further out in the mouth of Langford Creek. The Radial/Club 420 course (Charlie) will be in the Chester River.

Alpha (VHF Ch 68)	Bravo (VHF Ch 69)	Charlie (VHF Ch 71)
Opti Green	Opti White, Blue, Red	Laser Radial, C420

11. THE COURSES

- 11.1 The diagrams in Illustration B show the course(s), the order of rounding, and the side on which each mark is to be rounded or passed.
- 11.2 The race committee may change a leg of the course that begins at a rounding mark or at a gate to maintain course configuration relative to the prevailing wind direction by changing the position of the next mark (or the finishing line), provided that the next mark is in place before any boat begins the leg. This modifies RRS 33.

12. MARKS

Smaller orange spheres or hippety hops will be used on the Opti Green course (Alpha).
 Marks will be inflatable yellow cylinders on the Opti WBR course (Bravo).
 Marks will be inflatable orange tetrahedrons on the Laser Radial/420 course (Charlie).
 The starting and finishing marks on all courses will be orange hippety hops.
 Marks will be reviewed during the Skipper's meeting.

13. THE START

- 13.1 All fleets will be started in accordance with the 3-minute Audible-Signal Racing System as defined in Appendix U of the RRS. This changes RRS 26 and Race Signals.
- 13.2 The starting line will be between the staff from which a blue flag is displayed on the race committee signal boat and the course side of the starting pin.
- 13.3 Classes whose warning signal has not been made shall keep clear of the starting area and shall keep clear of all boats whose warning signal has been made.
- 13.4 A boat shall not start later than 3 minutes after her starting signal. Any boat starting later than 3 minutes after the start will be scored DNS.

14. INDIVIDUAL RECALLS

Individual recalls will be signaled in accordance with RRS 29.1. **The RC will not hail individual competitors.**

15. THE FINISH

The finishing line will be between a staff displaying a blue flag on a race committee boat and the course side of the nearby finish mark. All sailors must keep clear of the finish line after completing a race.



2018 Maryland State Championship

RHYC Junior One-Design Regatta

June 28-29, 2018

Rock Hall Yacht Club, Rock Hall, MD 21661

16. TIME LIMIT

- 16.1 The time limit will be 60 minutes for all classes.
- 16.2 The Race Committee may score boats in their position before the time limit is reached in an effort to expedite the start of the next race. This changes RRS 35.
- 16.3 Boats not finishing within the time limit will be scored DNS without a hearing. This changes RRS 35, A4, and A5

17. PROTESTS

- 17.1 Protests shall be in writing. Forms will be available from the Jury Secretary at the protest area in the RHYC Clubhouse, and must be delivered to the Jury Secretary within *60 minutes* after the time of the docking of the race committee signal boat for that competitor's course.
- 17.2 Protests will be heard in approximately the order of receipt as soon as possible.
- 17.3 Protest notices will be posted within **15 minutes** of the protest time limit to inform competitors where and when there is a hearing in which they are parties to a hearing or named as witnesses. This posting shall constitute the notification required by RRS 63.2 and RRS 61.1(b).
- 17.4 A boat is not permitted to protest another boat for breaking sailing instructions 3, 4, 19 & 20. This changes Rule 60.1(a). The penalty for breaking these instructions may be less than disqualification at the discretion of the protest committee.

18. SCORING

- 18.1 The Low-Point Scoring System, Appendix A of the RRS, will apply for all classes.
- 18.2 Optimist Dinghies other than Green Fleet shall be scored as an overall fleet, and shall be scored separately as Red, Blue and White fleets.
- 18.3 One race shall be completed to constitute a regatta.
- 18.4 If 5 or more races are sailed, a boat's worst score shall be discarded.

19. DISPOSAL OF TRASH

Boats observed purposefully discharging trash into the water will either be disqualified from all races the day the infraction is observed or be subject to other suitable disciplinary action, or both.

20. SUPPORT BOATS

- 20.1 Except as noted in 21.2, team leaders, coaches and other support personnel shall not be in the racing area from the time of the preparatory signal for the first class to start until all boats have finished or the race committee signals a postponement, general recall or abandonment. The penalty for failing to comply with this requirement may result in **disqualification of** all boats associated with the coach/support personnel who do so.
- 20.2 Optimist Green Fleet: coaching is encouraged during the starting sequence, around marks, and for staying generally "on course." Green Fleet support boats must identify themselves to the Race Committee and be careful not to interfere with any racing boats. Safety is paramount.
- 20.3 All support people – race committee, mark and safety boat operators, parents, etc. – are strongly encouraged to wear fully secured PFDs while on the water.



2018 Maryland State Championship

RHYC Junior One-Design Regatta

June 28-29, 2018

Rock Hall Yacht Club, Rock Hall, MD 21661

- 20.4 All coach boats and other support boats/support personnel must agree to aid any competitor in distress or requesting assistance of any sort.
- 20.5 Support boats shall complete registration indicating their CBYRA flag number (or “no flag available”).
- 20.6 Coaches shall display their club’s coach flag.
- 20.7 Coach and spectator boats shall monitor VHF channel 72 and shall immediately follow all instruction from the Race Committee and the Organizing Authority.
- 20.8 At no time shall any spectator, coach, or support boat interfere in the conduct of the race.
- 20.9 At no time during the course of any race shall any competitor approach or signal a spectator boat, nor shall a spectator boat approach or signal any competitor.
- 20.10 Any competitor associated with a coach, spectator or support boat breaking the instruction of this section is subject to a penalty up to and including disqualification for the relevant race.

21. PRIZES

Opti Green Fleet will have participation awards and finishing order will be announced.

Awards will be presented to the top three places, in each division, for the regatta overall.

An award will be presented to the top female skipper in the Optimist Class overall.

A Corinthian Spirit award will be presented to the sailor demonstrating the virtues of a Corinthian Sailor



2018 Maryland State Championship

RHYC Junior One-Design Regatta

June 28-29, 2018

Rock Hall Yacht Club, Rock Hall, MD 21661

Illustration A. Racing Area

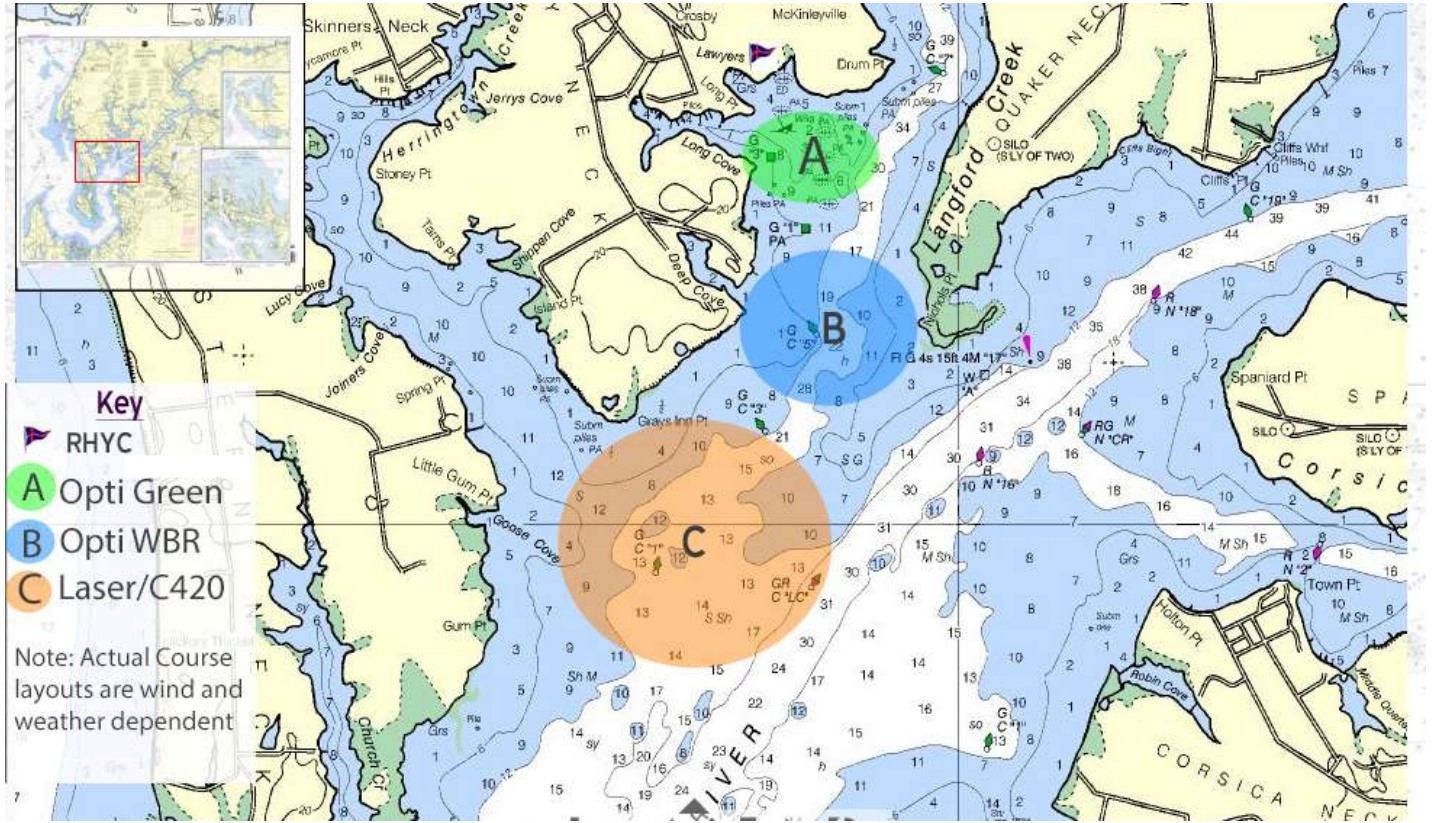



2018 Maryland State Championship

RHYC Junior One-Design Regatta

June 28-29, 2018

Rock Hall Yacht Club, Rock Hall, MD 21661

Illustration B. The Courses

A. OPTI GREEN – Modified Triangle

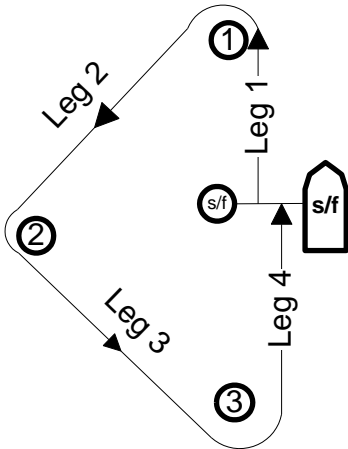

B. OPTI RBW – Modified Olympic

NOTE: Start/Finish line is closed

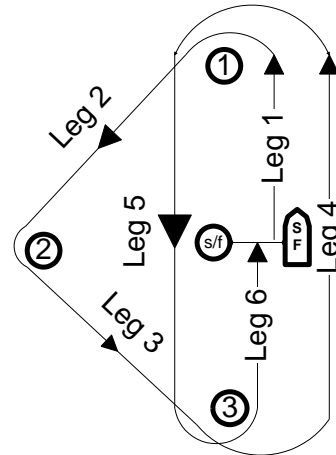

C. C420 / LASER RADIAL – Windward-Leeward (W1 and M1 shown, number of laps designated by R/C boat before the start). An offset mark may be used at the windward mark.

W1

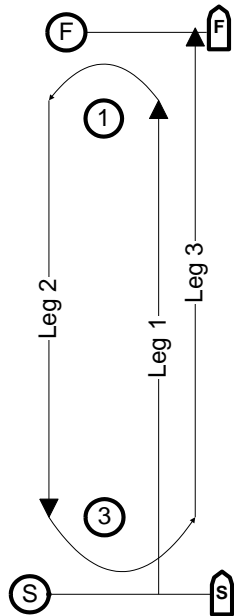

M1

