

SAILING INSTRUCTIONS

2019 Outer Cape Invitational

Hosted by the Orleans Yacht Club

Thursday, July 18th, 2019

Orleans Yacht Club | 39 Cove Road | PO Box 145 | Orleans, MA 02653 | (508) 255-9091

1. Rules

- a. The regatta will be governed by the rules as defined in the *Racing Rules of Sailing for 2017-2020* (RRS).

2. Notices to Competitors

- a. Notices to competitors will be posted in the tent area at the Orleans Yacht Club.

3. Signals Made Ashore

- a. Signals made ashore will be displayed on the OYC flagpole.
- b. If a postponement is signaled ashore, the warning signal will be made not less than 45 minutes after AP is lowered.

4. Schedule

- a. Thursday, July 18th:
 - i. 0800: Check-in & Breakfast at OYC
 - ii. 0900: Skippers' meeting outside OYC Clubhouse
 - iii. 0930: Harbor Start
 - iv. 1000: Approximate time of first race start
 - v. 1400: Approximate time of last race start
 - vi. Lunch and awards to follow

5. Racing Area

- a. The racing area will be Orleans Town Cove.

6. Check in/Check Out

- a. When arriving at the race course, each competitor must check in with the race committee boat by passing astern of the race committee boat on a starboard tack and hailing their sail number until acknowledged.
- b. Any sailor who decides to leave the race course prior to the conclusion of racing must check out with the race committee. This can be done by hailing the race committee boat directly or by alerting a coach or support boat, which will then alert the race committee via VHF radio.

7. Marks

- a. Turning marks will be yellow in color; the pin will be orange or pink in color.
- b. The Skippers' meeting will include a further description of all marks.

8. Race Committee Radio

- a. The race committee and all coach/support boats will communicate on VHF 72.

9. Courses

- a. The diagrams in Attachment A show the courses, including the order in which marks are to be passed and the side on which each mark is to be left.
- b. The race committee may signal that more than one lap of a course is to be sailed by appending the number of laps to the course letter (e.g., "D2" for 2 laps of course D)

SAILING INSTRUCTIONS

10. Starting and Finishing Lines

- a. The start/finish line will be between a mark and the OYC burgee on the committee boat.
- b. Either RRS 26 (5-minute start) or the 3-minute dinghy sequence will be used, at the discretion of the Race Committee. The starting sequence to be used will remain the same for the entire regatta and will be announced at the Skippers' meeting.
- c. In case of an individual recall, Race Committee may choose to announce the sail numbers of recalled boats, but is not obligated to do so. Failure to hear such an announcement does not absolve a recalled boat of its responsibility to comply with RRS 29.1 or 30 (over early).

11. Gate is Open

- a. Boats **may** pass through the start/finish line during a race other than to start or finish.

12. Protests

- a. A boat wishing to protest another boat shall:
 - i. Hail the other boat at the first reasonable opportunity.
 - ii. Report the protest to the Race Committee at the first reasonable opportunity, including the sail number(s) of the boat(s) being protested (usually, following the conclusion of the race).
- b. Protests shall be delivered to the Principal Race Officer within **30** minutes after the Race Committee boat docks. Hearings will be held as soon as possible after racing concludes.
- c. All protests will be heard by coaches of sailors **not involved** in the protest, whether such sailors are protesting or being protested. The Principal Race Officer reserves the right to select the protest committee.

13. Scoring

- a. The Low Point System of RRS Appendix A will apply.
- b. One race constitutes a series.
- c. For every five races sailed, one race will be excluded from each boat's series score (e.g., if ten races are sailed, two races will be excluded).

14. Trophies

- a. The skipper and crew of the top three boats will receive trophies.

SAILING INSTRUCTIONS

ATTACHMENT A: COURSE DIAGRAMS

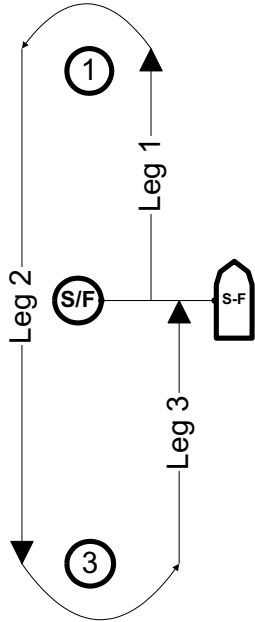

D

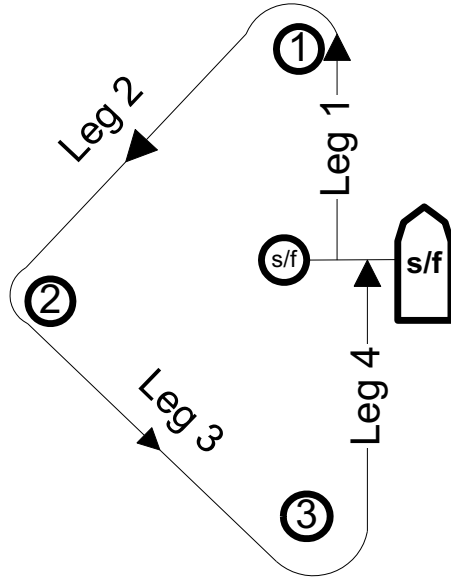

M

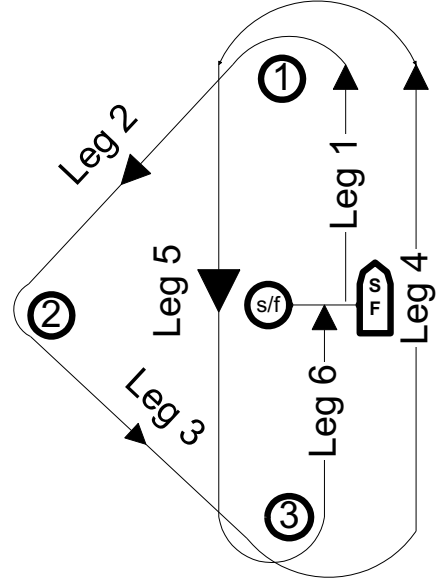

F