



55th ANNUAL DON Q SNIPE REGATTA
APRIL 9-11, 2021
COCONUT GROVE SAILING CLUB
& SNIPE FLEET #7
SAILING INSTRUCTIONS
Posted 4/6/2021



1. RULES:

- 1.1. The event will be governed by the *rules* as defined in the current edition of the *Racing Rules of Sailing* ("RRS"), the current SCIRA Class Rules, By-Laws, and the Rules of Conduct for Sanctioned or Club/Fleet Regattas (ROC), and these Sailing Instructions (SI). The ROC are included as a race document on the Regatta Network event site.
- 1.2. The following Prescriptions of US Sailing are the only Prescriptions that will apply: Appendix R and prescriptions to RRS 60.3, 61.4, 67, 70.5(a) and 76.1.
- 1.3. The following racing rules are being amended by these SI: RRS 27.1, 30.4, 32, 33, 35, 44.3(c), 61, 62.2; Appendix A2, Appendix A5, Appendix A10; and Race Signals.
- 1.4. The following ROC are being amended by these SI: ROC 5 and 8.1.
- 1.5. In accordance with the SCIRA Advertising Prescription, this event shall comply with World Sailing Regulation 20.

2. NOTICE TO COMPETITORS:

- 2.1. All race documents, notices & results will be posted on the official notice board at Regatta Network. https://www.regattanetwork.com/event/21866#_newsroom. Failure of a boat to read any such postings will not be grounds for redress. This changes RRS 62.1(a).
- 2.2. On Thursday, April 8th, at 19:00, there will be a virtual competitor's briefing, via Zoom, available at <https://us02web.zoom.us/j/81935036929?pwd=NGZYaG9uem9GbS9qTmt2RUxZTEc3UT09>
Or phone only: 1 301 715 8592 Meeting ID: 819 3503 6929 Passcode: 664967
- 2.3. The Race Committee (RC) will be using VHF channel 73.

3. CHANGES TO SAILING INSTRUCTIONS:

- 3.1. Any change to the SI will be posted no later than 90 minutes before the next warning signal, except that any change to the schedule of races will be posted by 1900 hours on the day before it will take effect.
- 3.2. Any change or amendment to the SI shall have the prior approval of the Regatta Chairman and the PRO.
- 3.3. Oral changes to the SI may be given on the water. The RC signal boat shall display flag "L" and announce any changes to the SI, via megaphone, in accordance with RRS 90.2(c). Competitors may also approach the signal boat and verbally receive the change or read it from a whiteboard while flag "L" is displayed.

4. SIGNALS MADE ASHORE:

- 4.1. Signals made ashore will be displayed at the CGSC flag hoist.
- 4.2. When flag AP is displayed ashore, "1 minute" is replaced with "not less than sixty (60) minutes" in the race signal AP. This changes RRS Race Signals.
- 4.3. In the event of an onshore postponement, the RC will communicate to competitors via VHF radio and by using their registered email, notifying competitors to check the on-line notice board.

5. SCHEDULE OF RACES:

- 5.1. The maximum number of races to be sailed is eight (8).
- 5.2. The maximum number of races that can be sailed on one day is three (3).
- 5.3. First warning signal will sound at 1200 on Friday and at 1100 on Saturday and Sunday.
- 5.4. No warning signal will be made after 1430 on Sunday.
- 5.5. One (1) race will constitute a series for this event.

6. CLASS FLAG: The Class Flag will be a white flag with the blue Snipe insignia/emblem.

7. RACING AREA: The Racing Area will be on Biscayne Bay SE of Brennan Channel, just beyond Middle Ground Shoal and south of Dinner Key Channel.

8. COURSES & CONDITIONS:

- 8.1 The diagram in Attachment "A" shows the courses, the order in which the marks are to be passed, and the side on which each mark is to be left. The course length will be based on sailing conditions. This changes ROC 5.
- 8.2 No later than one minute before the warning signal, the RC signal boat will display the course to be sailed. This changes RRS 27.1.
 - 8.2.1 For courses finishing to windward: flag "O" for the Olympic course, flag "T" for the Triangle course, and flag "W" for the Windward Leeward
 - 8.2.2 For courses finishing to leeward: flags "OD" for the Gold Cup course, flags "TD" for the Triangle course, and flags "WD" for the Windward Leeward.
- 8.3. The course signal flag will be accompanied by one (1) sound signal when displayed and will remain displayed for four (4) minutes after the start. Timely removal of course flag shall not be grounds for redress. This adds to RRS 27.1.
- 8.4. The approximate compass bearing to Mark 1 will be displayed by a numerical posting on a board on the RC signal boat before the preparatory signal.
- 8.5. All marks must be left to port unless it is a gate or the "start/finish mark" when finishing.
- 8.6. No race will be started in less than a sustained 4 knots of wind. However, the RC, may, in its discretion, decline to begin a race in less than a sustained 5 knots of wind. This changes ROC 9.1.
- 8.7. No race will be started in more than 23 knots of sustained wind, or in conditions where the winds are gusting to more than 27 knots. The RC may postpone any race if there are sustained winds over 18 knots.

9. MARKS:

- 9.1. Marks 1, 2 and 3s/p will be orange tetrahedrons.
- 9.2. Any start or finish mark (Mark S), if one is set, will be a yellow tetrahedron.
- 9.3. For the Windward/Leeward course(s) only (course "W" or "WD")
 - 9.3.1 An orange mark will be set as an offset **approximately** sixty feet to port of Mark 1.
 - 9.3.2 Mark 3 in the course diagrams will be a leeward gate, Marks 3s/p. In the event a single Mark 3 is established instead of a gate, the single mark shall be left to port.
- 9.4. Marks 3s/p are not marks of the course when completing the second lap of course "WD".
- 9.5. The RC signal boat may set an inflatable buoy attached to its stern. The inflatable buoy and its attachment line are a limit mark and must be left to starboard when starting, and when finishing downwind it must be left to port.

10. THE START:

- 10.1. The starting line will be between a staff displaying an orange flag or shape on the RC boat at the starboard end and the port-end start/finish mark, or between staffs displaying orange flags on two RC boats.
- 10.2. No boat may start a race more than four (4) minutes after the starting signal for that race, and will be scored Did Not Start (DNS) without a hearing. This changes ROC 8.1, and RRS 35.
- 10.3. The starting line will be set approximately 90 meters (300 feet) downwind of Marks 3s/p. Marks 3s/p are not marks of the course for the first leg of the race.
- 10.4 Six (6) minutes before the start, the RC will make multiple short sounds as an alert to the warning signal.

11. CHANGE OF COURSE OR NEXT LEG OF THE COURSE:

- 11.1. Shortening or lengthening the next leg of the course may not be by more than 30% of the original leg length. This changes RRS 33.
- 11.2. The number of legs of a course may not be reduced until after the second windward leg has been completed. This changes RRS 32.
- 11.3. If the RC elects to change the course being sailed to a different designated course, such a change will be signaled in accordance with ROC 9.2, by the display of the appropriate flag or flags, accompanied by repetitive sounds before the lead boat rounds the mark at which such a change is signaled. This changes RRS 33.
- 11.4. Except at a gate, boats shall pass between the RC boat signaling the change and the nearby mark, leaving the mark to port and the RC boat to starboard.
- 11.5. If during a race the wind and/or wave action change to the point where the course would be inadvisable (See Course Selection Diagram), the RC may change the course to a "T", or "W" by displaying the appropriate course flag accompanied by repetitive sounds at any mark. This changes RRS 33.

11.6. When a change of course according to SI 11.5 is displayed, the finish line will continue to be the same as the original course finish line. The RC will not display code flag “D” when indicating a change of course which originally had a downwind finish.

12. THE FINISH:

- 12.1. For courses “W”, “T”, and “O”, the finish line shall be between a staff displaying a blue flag on a RC boat at the starboard end and Mark 1 at the port end.
- 12.2. For courses “WD”, “TD”, and “OD”, the finish line shall be between a staff displaying a blue flag or shape on the RC boat at the port end and the start/finish mark at the starboard end, or between staffs displaying blue flags on two RC boats.
- 12.3. The RC will display flag “A” while boats are finishing to indicate “No more racing for the day.”

13. PENALTIES:

- 13.1. Any competitor taking a penalty in accordance with RRS 44.1 or 44.2 (*Penalties at the time of an incident*) is requested to notify the RC promptly upon finishing that race and to inform the RC of the identity of the other boat involved. Did Not Finish (DNF) is changed to Disqualification (DSQ) in RRS 44.3(c).
- 13.2. Any boat failing to check-in (CNF), in accordance with SI 17.1 and 17.2, will receive a scoring penalty. Points will be added to its finishing position equal to 10% of the starters in that race. This changes RRS Appendix A10.
- 13.3. The black flag shall not be used. This changes RRS 30.4.
- 13.4. A boat failing to finish a race will be scored DNF without a hearing and will be awarded points equal to one more than the number of boats finishing that race. This changes RRS A5.2.
- 13.5. The penalty for boats found to have broken RRS 55 (*Trash Disposal*) will be 20% of the finishing place of that boat in the first race it sails on the day of the infraction.

14. TIME LIMIT:

- 14.1. The time limit for the first boat to finish shall be 65 minutes. Should the first boat fail to finish within the aforementioned time the RC shall abandon the race.
- 14.2. Should the first boat fail to complete the first lap within 30 minutes, the RC shall abandon the race. For the purpose of this Rule a lap shall mean the rounding of Marks 3s/p for the first time.
- 14.3. Boats failing to finish within 15 minutes after the first boat sails the course and finishes will be scored DNF, and one (1) point more than the number of boats finishing within the time limit, without a hearing. This changes RRS Appendix A5.

15. PROTEST AND REQUEST FOR REDRESS:

- 15.1. A competitor’s intent to protest shall be reported to the RC promptly upon finishing the race in which the incident occurred. This changes RRS 61. The protestor must still otherwise comply with RRS 61.
- 15.2. Protests must be filed within one (1) hour after the RC finish boat docking time or when a race is abandoned ashore. The protest time limit will be posted on the regatta website notice board.
- 15.3. Request for Redress filing time shall be no later than the protest time limit or 30 minutes after the incident or 30 minutes after the posting of penalty/decision, whichever is later. This changes RRS 62.2.
- 15.4. Scoring inquiries, **including potential redress requests relating to a starting penalty**, should be initiated by filling out the online Scoring Inquiry form at <https://docs.google.com/forms/d/e/1FAIpQLSc56x9WKwLpbLRiQE5NOPGtKmntlVJQTe6-IWplSqVouz5qIQ/viewform>. Alternatively, a completed Scoring Inquiry form may be photographed and emailed to ScoringInquiry@cgsc.org. Also, questions about the status of scoring inquiries can be emailed to ScoringInquiry@cgsc.org. The RC will investigate, get back to you, and attempt to resolve the issue. If the scoring inquiry turns into a redress request, then the redress time limit will have been satisfied if the Scoring Inquiry form was submitted before the redress time limit expired.
- 15.5. Protests and **requests for redress unrelated to a starting penalty** should be initiated by filling out the online Protest form at https://docs.google.com/forms/d/e/1FAIpQLSdzOkZE7vvK_iXfJzfTr2txULYBp3CoQjtoEphz2aVXlvU5IQ/viewform. Additionally, if a diagram is required, it should be photographed and emailed to Protest@cgsc.org. Alternatively, a completed Protest form may be photographed and emailed to Protest@cgsc.org. Also, questions about the status of protests and redress requests can be emailed to Protest@cgsc.org. Virtual Protest hearings will be conducted *via* Zoom.
- 15.6. Protest notices and hearing schedules specifying the protesting and protested parties will be posted no later than one-half hour after the expiration of the protest filing time limit. It is each boat’s sole responsibility to check the event website notice board or its e-mail promptly after the end of the protest

filing time to see if she is cited in a protest. Representatives of boats who are parties to hearings and their witnesses shall remain on call until excused by the Protest Committee.

16. SCORING:

16.1. One (1) completed race will constitute a series for this event.

16.2. A boat's series score will be the total of her race scores when five (5) or less races are completed. This changes RRS Appendix A2.1.

17. SAFETY REGULATIONS:

17.1. Each day before the start of the first race, but not before flag "L" is displayed, each boat is required to sail on starboard tack past the stern of the RC signal boat and verbally check in. When the RC verbally acknowledges a boat's sail number, the check-in has been officially noted.

17.2. A boat that retires from a race shall notify the RC as soon as possible.

18. REPLACEMENT OF CREW:

18.1. The same crew shall race in all races, except for reasons satisfactory to the RC.

18.2. Requests for the replacement of any member of the crew shall be submitted in writing to the PRO prior to 0900 on the day the change will take effect.

18.3. The request for replacement of any member of the crew requires the approval of the PRO.

18.4. Once a skipper and/or crew have been excused, they may not return for the balance of the series.

18.5. Co-skippers shall be allowed subject to the restrictions of SI18.1 and 18.2.

19. EQUIPMENT AND MEASUREMENT CHECKS:

19.1. The RC may inspect competitors or boats not racing at any time. Equipment inspections may be initiated at the finish of any race.

20. SUPPORT BOATS:

20.1. Coach vessels shall register with CGSC during Registration, receive a flag, and sign a credit card authorization. Upon request, a mooring ball will be assigned for overnight use. The vessel will be charged \$80 if the flag is not returned at the end of the regatta. No coach vessel will be allowed on the course without a flag.

20.2. No coach, other support or spectator vessels shall maneuver within 100 meters of the race course except to render assistance. Any competitor associated with personnel determined to have violated this rule shall be subject to protest and may be assessed a 20% penalty for the race in which the violation occurred.

20.3. Any coach, RC support boat, or spectator boat being operated in the immediate vicinity of, and associated with, this event shall have a kill switch lanyard attached to the operator as long as the engine is running.

21. VENUE:

21.1. The safety of sailors and volunteers is paramount. All skippers, crews and interested parties must comply with all CGSC Health protocols. Please remember to socially distance at least six feet away from others, to wear a mask at all times while ashore, regularly wash your hands, and avoid touching your face. If you have any symptoms of Covid-19 or are feeling unwell, you shall stay away from the event premises and competitors.

21.2. All skippers, crews and interested parties must properly dispose of trash while ashore at CGSC or afloat. Trash left on the ground will not be tolerated.

21.3. Further, while ashore, all skippers and crews are to promptly comply with instructions from the CGSC Staff. Failure to comply with SI 22 shall not be grounds for protest by a boat.

22. DISCLAIMER OF LIABILITY:

22.1. Competitors participate in the event entirely at their own risk. See RRS Rule 3, Decision to Race and RRS 4, Acceptance of Rules. The Organizing Authority will not accept any liability for material damage or personal injury or death sustained in conjunction with or prior to, during or after the regatta. **By entering this regatta, you accept this condition.**

ATTACHMENT A

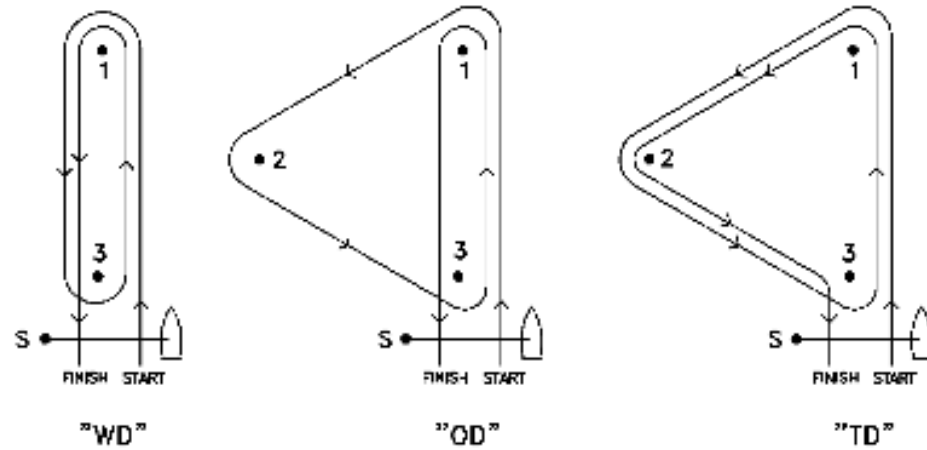
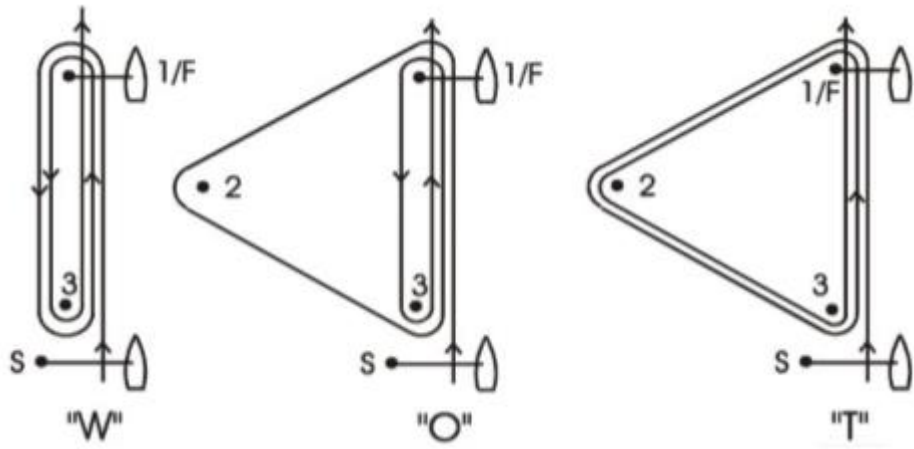

NOTE: for course W and WD ONLY:

- Offset at Mark 1
- Leeward gates, Mark 3s/p

No offset and no leeward gate will be used for courses T, TD, O or OD.