

Bottoms Up Regatta

SAILING INSTRUCTIONS



Organizing Authority and Host: Thistle Fleet 155 Jordan Lake, Vista Point April 24, 2021

1. RULES

The regatta will be governed by the rules as defined in The Racing Rules of Sailing.

2. CHANGES TO SAILING INSTRUCTIONS

- 2.1 Any change in the sailing instructions applying to Saturday will be posted to the Official Bulletin Board by 1130 Saturday.
- 2.2 Changes to a sailing instruction may be made on the water. Race Signal L will be displayed and all boats shall come within hail. Notification of the change will be given to, and acknowledgement received from each boat.

3. COMMUNICATIONS WITH COMPETITORS

- 3.1 Notices to competitors will be posted on the Official Bulletin Board located in the parking lot near the race committee signal vessel trailer.
- 3.2 On the water, the race committee intends to monitor and communicate with competitors on VHF channel 72.
- 3.3 The following communications will be made by race committee on VHF channel 72:
Safety and general information to assist in the management of the regatta (starting sequence time ticks, starting signals, recalls, etc.). This does not in any way alter the competitors' responsibility to observe the race committee's visual and sound signals which shall govern the conduct of racing.
- 3.4 [DP] While racing, except in an emergency, a boat shall not make voice or data transmissions and shall not receive voice or data communication that is not available to all boats.

4. SIGNALS MADE ASHORE

- 4.1 Signals made ashore will be displayed from the race committee signal vessel.
- 4.2 When flag AP is displayed ashore, '1 minute' is replaced with 'not less than 30 minutes' in the race signal AP.

5. SCHEDULE OF RACES

- 5.1 Five races are scheduled as follows:
Saturday, April 24
1200 Launch boats.
1300 Warning signal for race one.
Successive races will follow as soon as practicable.
No warning signal will be made after 1730.
- 5.2 Flag A displayed, with no sound, while boats are finishing means 'No more racing today.'

6. CLASS FLAG

The class flag will be the Thistle Class flag.

7. RACING AREA

The racing area will be approximately .5 nautical mile east of the Vista Point boat ramps.

8. COURSES

8.1 The diagrams in Illustration A show the courses, including the order in which marks are to be passed, the side on which each mark is to be left.

8.2 No later than the warning signal, the race committee signal vessel will display the course to be sailed and the approximate compass bearing of the first leg.

9. MARKS

9.1 Marks 1 and 3 will be orange cylinders.

9.2 Mark 1a, offset mark, will be a yellow tetrahedron.

9.3 A new mark, as provided in SI 11, will be a yellow cylinder.

9.4 The starting and finishing marks will be pink balls.

10. THE START

10.1 The starting line will be between a staff displaying an orange flag on the race committee signal vessel boat and the course side of the port-end starting mark described in SI 9.4.

10.2 In addition to RRS 29.1, Race Committee will attempt to broadcast the sail number of each individual recalled boat on VHF channel 72. Failure to make a broadcast or to time it accurately will not be grounds for a request for redress. This changes RRS 62.1(a).

11. CHANGE OF THE NEXT LEG OF THE COURSE

To change the next leg of the course, the Race Committee will lay a new mark and remove the original mark as soon as practicable. When in a subsequent change a new mark is replaced, it will be replaced by the original mark. There will be an offset mark for new or subsequent marks.

12. THE FINISH

The finishing line will be between a staff displaying a blue flag on a race committee boat and the course side of the finishing mark described in SI 9.4. Boats should cross the finish line in the direction from the last mark.

13. PENALTY SYSTEM

13.1 Alternative Penalties: RRS V1 and V2 shall apply.

13.2 RRS V1 - Penalty at The Time of the Incident

The first two sentences of rule 44.1 are changed to: 'A boat may take a One-Turn Penalty when she may have broken one or more rules of Part 2 or rule 31 in an incident while racing. However, when she may have broken one or more rules of Part 2 while in the zone around a mark other than a starting mark, her penalty shall be a Two-Turns Penalty.'

13.3 RRS V2 – Post-Race Penalties

(a) Provided that rule 44.1(b) does not apply, a boat that may have broken one or more rules of Part 2 or rule 31 in an incident may take a Post-Race Penalty at any time after the race until the beginning of a protest hearing involving the incident.

(b) A Post-Race Penalty is a 30% Scoring Penalty calculated as stated in rule 44.3(c). However, rule 44.1(a) applies.

(c) A boat takes a Post-Race Penalty by delivering to the race office a written statement that she accepts the penalty and that identifies the race number and where and when the incident occurred.

14. TIME LIMITS

- 14.1** The time limit for the first boat to sail the course and finish is 90 minutes.
- 14.2** Boats failing to finish with 30 minutes after the first boat sails the course and finishes will be scored TLE (Time Limit Expired) without a hearing and will receive a score equal to the number of boats that have finished within the time limit + 2, not to exceed the number of boats in the race. This changes RRS 35, 63.1, A4, A5, and A11.

15. HEARING REQUESTS

- 15.1** The protest time limit is 45 minutes after the race committee signal vessel returns to the dock and sounds a horn.
- 15.2** Hearing request forms will be available at the race committee signal boat trailer in the parking lot.
- 15.3** Notices will be posted no more than 30 minutes after the protest time limit to inform competitors of hearings in which they are parties or named witnesses.

16. SCORING

- 16.1** One race completed is required to constitute the regatta.
- 16.2** A boat's regatta score shall be the total of all of her races

17. SAFETY REGULATIONS

- 17.1** [DP] Prior to the first warning signal each day of sailing, each boat shall sail by the stern of the race committee signal vessel, hail her sail number to check-in, and receive an acknowledgment from the Race Committee.
- 17.2** [DP] A boat that retires from a race shall notify the Race Committee as soon as possible.

18. OFFICIAL VESSELS

Official vessels will be marked as follows:
Signal vessel – blue RC flag
Mark \ windward finish vessels – yellow RC flags

19. TRASH DISPOSAL

Trash may be placed upon official vessels.

20. PRIZES

Prizes will be given.

21. RISK STATEMENT

RRS 3 states: 'The responsibility for a boat's decision to participate in a race or to continue to race is hers alone.' By participating in this event each competitor agrees and acknowledges that sailing is a potentially dangerous activity with inherent risks. These risks include strong winds and rough seas, sudden changes in weather, failure of equipment, boat handling errors, poor seamanship by other boats, loss of balance on an unstable platform and fatigue resulting in increased risk of injury. **Inherent in the sport of sailing is the risk of permanent, catastrophic injury or death by drowning, trauma, hypothermia or other causes.**

Illustration A

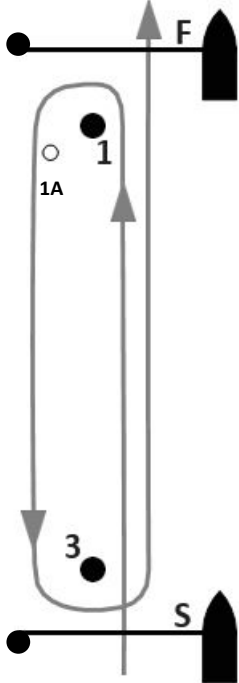
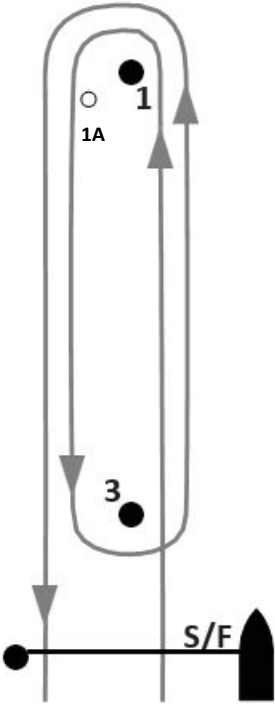
<p style="text-align: center;">WL (Windward Start, Windward Finish)</p> 	<p style="text-align: center;">WD (Windward Start, Downwind Finish)</p> 
<p>Course WL will be S-1-1A-3-F.</p> <p>Course WL2 will be course WL with an additional weather leg and leeward leg: S-1-1A-3-1-1A-3-F.</p>	<p>Course WD will be S-1-1A-3-1-1A-F.</p> <p>Course WD2 will be course WD with an additional weather leg and leeward leg: S-1-1A-3-1-1A-3-1-1A-F.</p>