



GSBYRA Queen of the Bay Race

Bellport Bay Yacht Club

Sept 5, 2021



Sailing Instructions

Posted 8/05/21

1. RULES

- 1.1. The race will be governed by the *rules* as defined in *The Racing Rules of Sailing, 2021–2024*, the prescriptions of the United States Sailing Association, class rules, the rules, regulations, and conditions of Queen of the Bay.
- 1.2. Portsmouth Number handicaps will be used to determine corrected times for all boats.

2. DISCLAIMER OF LIABILITY

Competitors participate in the race entirely at their own risk. See RRS 3, Decision to Race. The Bellport Bay Yacht Club, Officers, and Members will not accept any liability for material damage or personal injury or death sustained in conjunction with or prior to, during, or after the race.

3. NOTICE TO COMPETITORS & CHANGES TO THE SAILING INSTRUCTIONS

- 3.1 Notices will be posted on the official bulletin board located in the club on the day it will take effect, 1 hour before the race.
- 3.2 Signals made ashore will be displayed on the flagpole in front of the club.

4. SCHEDULE OF THE RACE

Sunday, September 5, 2021 1100 Warning Signal for all boats to start at the same time on the same line

5. COURSES

The diagrams below show the courses, the order in which marks are to be rounded or passed, and the side on which each mark is to be left. Courses will be designated by a Code Flag A, or B or C.

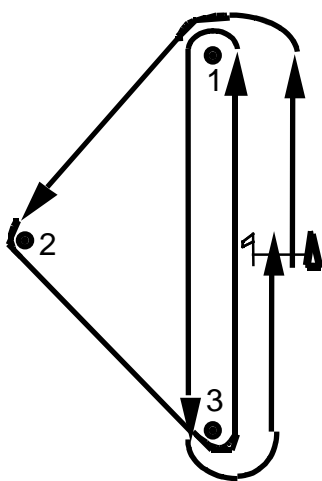

Course A

Start-1-2-3-1-3-finish

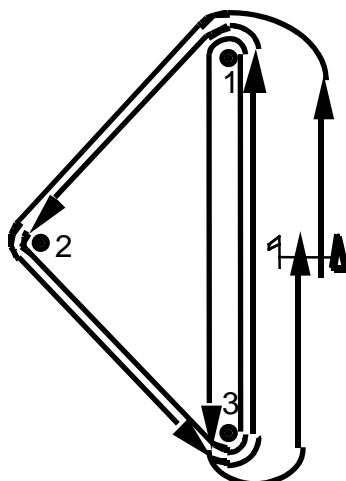

Course B

Start-1-2-3-1-2-3-1-3-finish

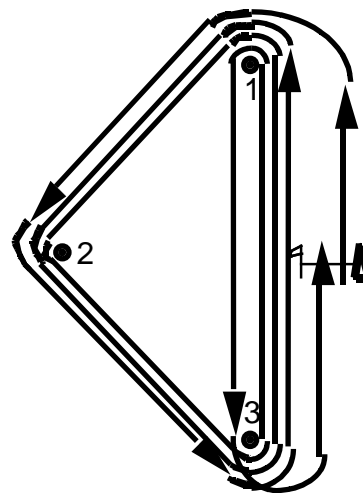

Course C

Start-1-2-3-1-2-3-1-2-3-1-3-finish

6. **MARKS** will be large orange inflatable cylinders and the Pin the port end of the Start/Finish line will be a large orange cylinder.
7. **VISUAL SIGNALS DISPLAYED ON THE FLAGPOLE IN FRONT OF THE CLUB OR DISPLAYED ON THE RACE COMMITTEE BOAT**
 - 7.1 When Race Signal AP is displayed ashore, “1 minute” is replaced with “not less than 30 minutes” in the Race Signal AP. This changes Race Signal AP.

8. START/FINISH

- 8.1 The start and finish line will be between a staff displaying an orange flag on the race committee boat at the starboard end and the course side of the orange inflatable cylinder at the port end starting mark.
- 8.2 The race will be started in accordance with racing Rule 26, with all yachts starting together.

		Flag	Signal Sound	Time before Start
1100	Warning	Blue Flag Displayed	1 sound	5 minutes
	Preparatory	P, or I Flag Displayed	1 sound	4 minutes
		P, or I Flag Removed	1 long sound	1 minute
	Start	Blue Flag Removed	1 sound	

9. OBSTRUCTION

- 9.1 The start/finish line is designated an obstruction. After starting, boats may not cross the start/finish line in either direction except when finishing.
- 9.2 The boat may not correct its error and the penalty is disqualification. This changes Rule 28.2.

10. PERSONAL FLOTATION

Competitors in One Design Class boats shall wear a personal flotation device except while briefly changing or adjusting clothing or personal equipment. Wet suits and dry suits are not personal flotation devices.

11. WITHDRAWAL

A yacht when withdrawing shall make every effort to notify the Race Committee as soon as possible.

12. TIME LIMIT is 3 and 1/2 hours for all yachts to finish.

13. HEARING REQUESTS

- 13.1 The Protest Time Limit is 1 hour after the Race Committee boat docks for the day. The time will be posted on the Official Notice Board.
- 13.2 Hearing request forms are available at the Registration desk.
- 13.3 Hearings will be posted on the Official Notice Board.

14. SCORING FOR THE RACE is based on the following:

- 14.1 The first eligible conventional yacht to finish with the lowest elapsed time will receive the Growtage Bowl.
- 14.2 The first eligible yacht, regardless of hull type or rig, to finish with the lowest elapsed time will receive the Everitt Trophy.
- 14.3 The first eligible conventional yacht to finish with the lowest corrected time based on current GSBYRA Portsmouth numbers will receive the Patchogue Advance Trophy.
- 14.4 The first eligible multi-hull yacht to finish with the lowest corrected time based on current GSBYRA Portsmouth numbers will receive the Gallina Trophy.
- 14.5 The official GSBYRA season scorer verifies eligibility of all competitors.

15. PRIZES

- 15.1 Prizes will be awarded at the 2021 GSBYRA Fall Awards Dinner, Saturday November 20, at Sayville Yacht Club.
- 15.2 Winners receive a keeper trophy and have their names engraved on the four Perpetual Trophies, which are on display at the Long Island Maritime Museum during the year.