



# SAN JUAN 21 NORTH AMERICANS

Sanford, Florida – January 13<sup>th</sup> – 15<sup>th</sup> 2023

*Organizing Authority: Lake Monroe Sailing Association and Fleets*

## SUPPLEMENTARY SAILING INSTRUCTIONS

1. All RRS formerly requirements that a Rule included in the Notice of Race be repeated in the sailing instructions have been removed.

### Schedule of Races

Friday, January 13<sup>th</sup>

0830 - 1000 Registration and sail inspection

1030 Competitors Meeting

1155 First warning signal, additional races to follow

1800 Dinner

Saturday, January 14<sup>th</sup>

0955 First warning signal, additional races to follow

No races after 1500

Sunday, January 15<sup>th</sup>

\*If needed to finish regatta, schedule will be posted

On the last day of the regatta if three races have been completed no warning signal will be made after 1400.

2. Location of race office and the flagpole on which signals made ashore will be displayed: Lake Monroe Sailing Association office, 531 N. Palmetto Avenue, Sanford FL 32771. The flagpole is adjacent to the LMSA office and is visible from the launching ramp on Marina Isle.

3. A list of the marks and class flag that will be used and a description of each one.

Mark 1 - Yellow inflatable

Mark 1a - Inflatable ball (“hippity hop”)

Mark 2, 2s and 2p - Yellow inflatable

Mark 3 - Yellow Wing inflatable

Starting mark - Orange inflatable

How new marks will differ from original marks: New marks will be orange inflatables.

Class Flag: Will be posted to board office before to Competitors.

4. Time limit: 90 minutes. Boats still racing 30 minutes after the first boat sails the course and finishes will be scored DNF, the position of the last boat that complies with RRS 28 to finish plus 2. If no boat rounds the first mark within forty (40) minutes, the race shall be abandoned and, if possible, resailed. This changes Class Rule VIII.3, RRS 35, A4.2, and A11.

5. Any changes or additions to the Standard Sailing Instructions

A. The following Rules in the Racing Rules of Sailing are modified:

i. After the start, minor adjustments in a mark's location will not be signaled. This changes RRS 33.

ii. When flag Y is displayed on shore, this rule applies at all times while afloat. This is new RRS Rule 40. US Sailing's prescription to rule 40 is deleted.

iii. These Sailing Instructions may be changed orally on the water; the Signal Vessel will fly Code Flag L with multiple sound signals in the event of a change in the Sailing Instructions. This implements Appendix J2.2(10).

iv. RRS 42.3[c] is changed: "Except on a beat to windward, when surfing down the leeward side of a wave or planing is possible, a boat's crew may pull/**pump** the sheet, but not the guy, controlling any sail to initiate surfing or planing, but only once for each wave or gust of wind. When the mainsail is pumped, only that part of the sheet between the crew member handling the sheet and the first block on the boom shall be used."

v. Equipment protests shall be accepted only from the Race Committee. This changes Rule 60.1.

vi. VHF radios are allowed for safety communications with the Race Committee (RC).

A. Use of handheld VHF radios will be permitted only for communication from the Race Committee to competitors on Channel 72. Such radios are "Safety Equipment." The Race Committee intends to use VHF radio to identify OCS (On Course Side of the line) boats after starts and otherwise communicate with the fleet on the water. Failure to receive a hail, for a hail to be made, the order of hails made, or receive other communications to the fleet shall not be cause for redress.

B. Other use of any communication device is prohibited, and such use shall require withdrawal from the race unless determined by the Race Committee to have been for emergency purposes. Failure to receive a hail, for a hail to be made, the order of hails made, or receive other communications to the fleet shall not be cause for redress.

viii. A boat intending to protest about an incident that occurs in the racing area shall notify the RC finish boat of her intention after the finish of that race, including the sail number of the boat (s) being protested. This changes RRS 61.1 (a).

6. Under Rule 87, ILCA Class Rules are changed as follows: Boats are not required to carry an anchor, but all other equipment in accordance with VI.2 is required.

7. The Start. A boat that has not started before 5 minutes after her starting signal shall be scored DNS.

8. Recalls: Following the display of the Individual Recall signal, the RC will attempt to announce by VHF radio the sail or bow numbers of all boats identified on the course side of the starting line at the start signal and boats that must comply with Rule 30.1. Such announcements are a courtesy and failure by the RC to make the announcement, or of boats to hear and/or understand it, shall not constitute grounds for redress. This changes RRS 62.1(a).

9. The Finish. Flag "A" displayed with no sound while boats are finishing indicates "no more racing today." Flag "R" displayed with no sound while boats are finishing indicates "racing will continue after a break either on shore or on the water." If no flag is flying it may be assumed that another race will follow immediately. Note that the finish line is now the Orange flag on Signal Boat and a Blue flag if a mark boat in position, or Orange mark if no mark boat in position. This change RRS "Flags"

10. The crew of a capsized boat or a crew member overboard shall be considered "in danger", and thus eligible to continue racing without penalty after receiving assistance. This changes RRS 41. New "V" flag (large White with a Red "X"), all boats (including all coaches, etc.) must, if possible, monitor the race committee communication channel 72 for search and rescue instructions. RRS 40 (PFDs) has been rewritten.

11. A boat leaving the racing area shall communicate her intention by radio to the Race Committee or by telephone to Lake Monroe Sailing Association at (321) 578-8364.

## COURSES:

### WINDWARD-LEEWARD:

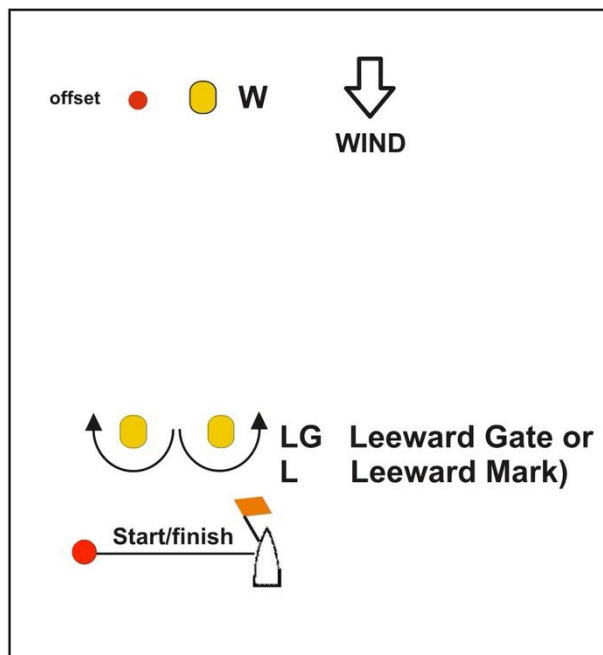

### THE TRIANGLE COURSE:

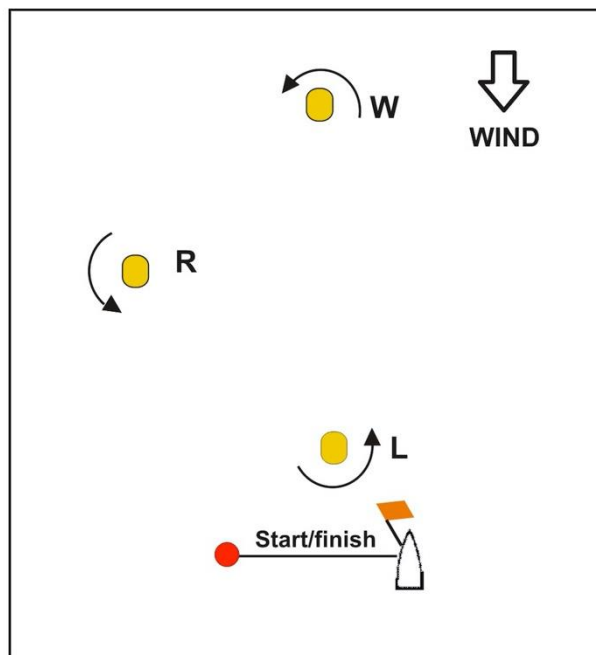

### WINDWARD/LEEWARD COURSES (W/L): \*

- 2 W/L Start, W, Finish
- 4 W/L 2X Start, W, L, W, Finish
- 6 W/L 3X Start, W, L, W, L, W, Finish

\* Leave the windward mark and offset (if there is one) to port.  
If there is a gate at the bottom, use either side of the gate.

### TRIANGLE-WINDWARD/LEEWARD COURSES (T-W/L): \*\*

- 5T T-WL Start, W, R, L, W, Finish (Triangle, + windward-leeward)

\*\* Leave all marks to port.

If there is a triangle course for one or more classes, there will be no offset at the top and no gate at the bottom.