



2022 Snipe US Masters National Championship



SNIFE CLASS INTERNATIONAL RACING ASSOCIATION
September 30 – October 2, 2022
Perry Yacht Club, 8369 Yacht Club Drive, Meriden, KS (USA)

SAILING INSTRUCTIONS (SIs)

The notation [NP] in a rule in the SI means that a breach of this rule shall not be grounds for a protest by a boat.

1. RULES

- a. The regatta will be governed by the rules as defined in *The Racing Rules of Sailing*.

2. CHANGES TO SAILING INSTRUCTIONS

- a. Any changes to the sailing instructions will be posted before 0900 hrs on the day it will take effect, except that any change to the schedule of races will be posted by 2000 hrs on the day before it will take effect.
- b. Except in event of a postponement signalled on shore, the SIs may be changed 15 minutes prior to the removal of the AP signal.
- c. Changes to a sailing instruction may be made on the water by the race committee signal vessel by displaying flag "L" with one sound signal and announcing the change. Boats shall sail astern of the signal vessel on starboard tack to receive the change and acknowledge their understanding of the change. This change is made in accordance with rule 90.2(c).

3. COMMUNICATIONS WITH COMPETITORS

- a. Notices to competitors will be posted on the official notice board located at the northwest corner of the PYC Pavilion.
- b. On the water, the race committee (RC) will make courtesy and safety broadcasts to the competitors on marine VHF channel 69.
 - b.i. Information reported by the RC is provided as a courtesy to competitors, failure to hear any information provided will not be grounds for redress or request. This changes RRS 62.1.

4. CODE OF CONDUCT

- a. [DP] Competitors and support persons shall comply with reasonable requests from the race officials.

5. SIGNALS MADE ASHORE

- a. Signals made ashore will be displayed on the flagstaff located north of the PYC pavilion.
- b. When flag "AP" is displayed ashore, "1 minute" is replaced with "not less than 30 minutes" in the race signals "AP", this changes RRS Race Signals.

6. SCHEDULE OF RACES

- a. Warning for the practice race is scheduled for 1430 hours on Friday, September 30, 2022.
- b. Competitors meeting will be held at the pavilion at 1100 hrs on October 1, 2022.
- c. The warning of the first race on October 1, 2022, will be at 1330 hrs.
- d. The warning of the first race on October 2, 2022, will be at 1000 hrs.
- e. On the last scheduled day of racing no warning signal will be made after 1300 hrs.

7. CLASS FLAG

- a. The class flag for the start will be posted on the official notice board prior to 0900 on October 1, 2022.

8. RACING AREA

- a. The racing area will be the waters of Perry Lake, directly east of the Perry Yacht Club.

9. COURSES

- a. Appendix A shows the class approved courses that may be used for this event.
- b. The course designation and the compass bearing to the windward mark will be posted on the signal vessel prior to the warning signal.

- c. Marks 3s and 3p will designate the gate. If the gate is not in place, the single mark shall be left to port.
- d. Mark 1 will have an offset mark designated as mark 1a. If the offset mark is not in place, the single windward Mark 1 shall be left to port. Marks 3s and 3p will designate the gate. If the gate is not in place, the single mark shall be left to port.

10. **MARKS**

- a. The windward mark will be an orange tetrahedron, the windward offset mark will be a red ball, and the leeward gate will be red cylinders.
- b. The starting and finishing mark will be a yellow cylinder.
- c. Change marks will be a yellow inflatable cylinder.

11. **OBSTRUCTIONS**

- a. [DP] While racing no boat shall cross a line created by adjacent white caution buoys and the nearest shore at Grabber’s Point.

12. **THE START**

- a. The starting line is between a staff displaying an orange flag on the signal vessel at the starboard end of the course side of the port end of the starting mark.
- b. A boat that does not start within 5 minutes of her starting signal will be scored Did Not Start (DNS) without a hearing. This changes RRS A5.1 and A5.2.

13. **CHANGE OF THE NEXT LEG OF THE COURSE**

- a. To change the next leg of the course, the race committee will lay a new mark and remove the original mark as soon as practicable. When in a subsequent change a new mark is replaced, it will be replaced by the original mark.
- b. Offset marks will not be set on a changed leg of the course. This changes RRS 33 (c).
- c. The RC may make minor changes to the orientation of the course, without signaling a change of course. This changes RRS 33 (a).

14. **THE FINISH**

- a. The finish line is between a staff displaying a blue flag on the RC vessel and the yellow mark.

15. **TIME LIMITS**

- a. The Mark 1 Time Limit, Race Time Limit (see RRS 35), and the Finishing Window are shown in the table below.

Mark 1 Time Limit	Race Time Limit	Finishing Window
30 min	120 min	20 min

- b. If no boat has passed the first mark within the “Mark 1 Time Limit”, the race will be abandoned.
- c. The Finishing Window is the time for boats to finish after the first boat sails the course and finishes. Boats failing to finish within the Finishing Window, and not subsequently retiring, penalized or given redress, that are still racing, will be scored time limit expired (TLE) without a hearing. A boat scored TLE shall be scored points for the finishing place one more than the points scored by the last boat within the Finishing Window. This changes RRS 35, A5.1, A5.2 and A10.

16. **HEARING REQUESTS**

- a. The protest time limit is 90 minutes after the last boat finishes the last race of the day or the race committee signals no more racing today, whichever is later. The protest time limit will be posted on the official notice board.
- b. Hearing request forms are available on the official notice board.
- c. Notices will be posted no later than 30 minutes after the protest time limit to inform competitors of hearings in which they are parties or named as witnesses. The location of the protest will be posted with the notice.

17. **SCORING**

- a. One race is required to be completed to constitute a series.
- b. A boat’s series score is the total of her race scores.

18. **SAFETY REGULATIONS**

- a. [DP] A boat that retires shall notify the RC at the first reasonable opportunity.
- b. [DP] Prior to the warning of the first start of the first race each day, each boat shall check-in with and be recognized by the signal vessel displaying flag "L" by passing close astern on starboard tack and hailing her sail number. The signal vessel will acknowledge the hail.

19. **TRASH DISPOSAL**

- a. Trash may be placed aboard official RC vessels.

20. **RISK STATEMENT**

- a. Competitors participate in this regatta entirely at their own risk. See rule 3, Decision to Race. Competitors acknowledge that sailing involves potential risks. As a condition of their participation in this regatta, competitors release all claims they may have against the OA, Perry Yacht Club, SCIRA USA and its officers, directors, members, committees, and employees for damage to property, personal injury or death sustained in conjunction with or prior to, during or after the regatta. Competitors shall be responsible for damage or injury caused by their breach of the Racing Rules of Sailing or applicable governmental rules for the avoidance of collision.

APPENDIX A - THE COURSES

The diagrams below show the courses, including the approximate angles between legs, the order in which marks are to be passed. All course marks (except gates) shall be left to port.

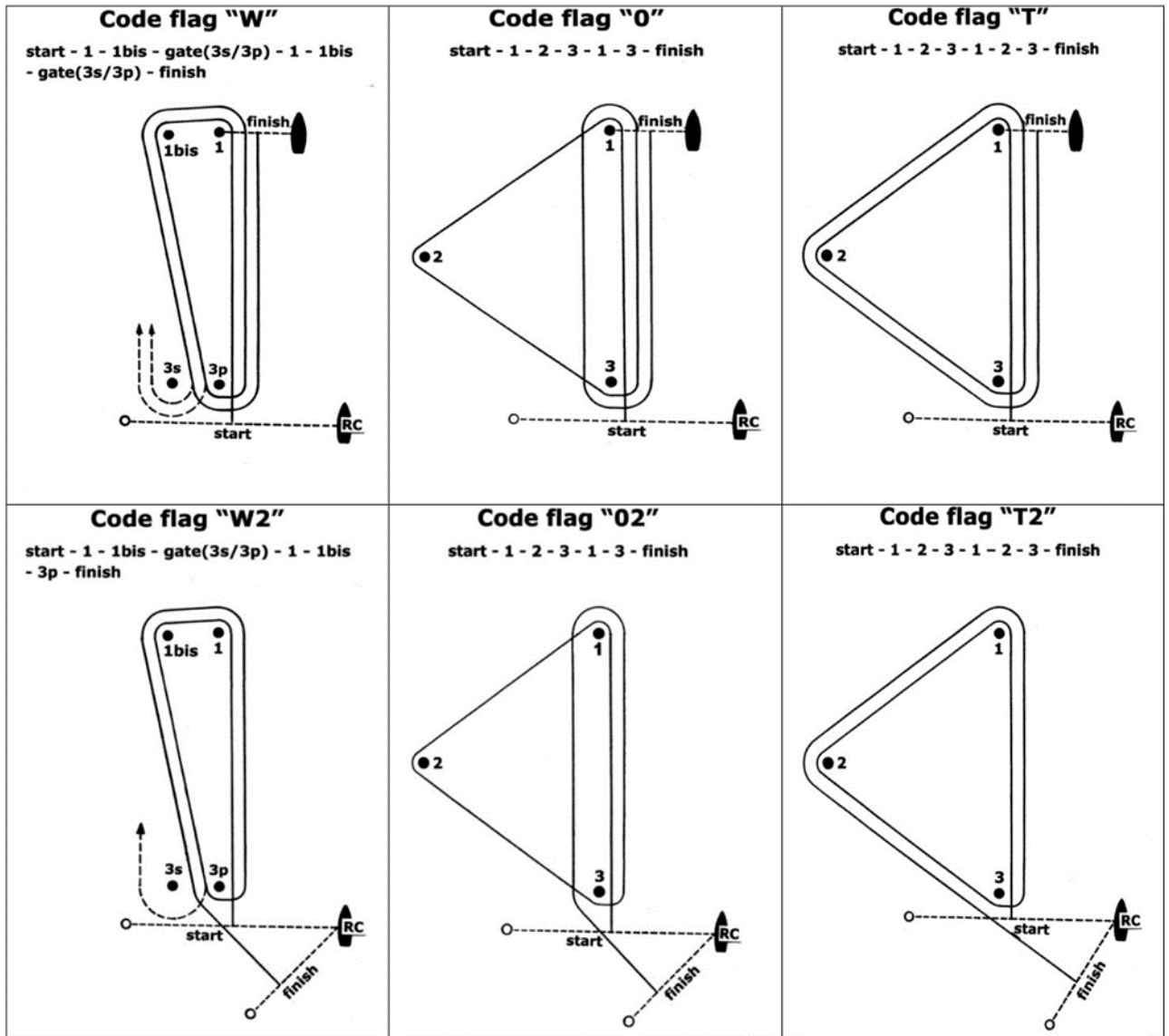

The course signal ("W", "T", "O", "W2", "T2" or "O2") will be posted on the Signal vessel.