



**2022 Snipe US Masters National Championship**  
Snipe Class International Racing Association (SCIRA) USA  
Hosted by: Perry Yacht Club (PYC) and SCIRA USA District 2



September 30 - October 2, 2022

Perry Yacht Club  
8369 Yacht Club Dr.  
Meriden, KS, 66512 USA

**Notice of Race (NoR)**

**1. RULES**

- a. The event will be governed by the rules as defined in *The Racing Rules of Sailing*.
- b. All boats and crew are required to abide by federal, state, local laws, guidelines, restrictions for the operation of a boat on Perry Lake.
- c. The SCIRA Conduct for Conducting National and Local Regattas (RoC).
- d. The SCIRA USA Masters Championship Deed of Gift.

**2. SAILING INSTRUCTIONS**

- a. The sailing instructions (SIs) will be available on Regatta Network (<https://www.regattanetwork.com/event/24710>) prior to September 24, 2022.

**3. ELIGIBILITY AND ENTRY**

- a. The event is open to SCIRA registered boats and Class Member skippers and crews who are in good standing with SCIRA for the current year, subject to any Deed of Gift restrictions,
- b. Eligible boats may enter by completing the entry form located on Regatta Network and submitting it, together with the required fee,
- c. The skipper of the boat shall be at least 45 years of age in the year of the regatta. The combined age of the skipper and crew shall be at least 80 years in the year of the regatta, per the SCIRA USA Masters Championship Deed of Gift.

**4. FEES**

- a. The entry fee for the event is \$160.00 until September 20, 2022. After this date, the fee will increase by \$25.00 as a late fee.
- b. The entry fee includes social package consisting of daily breakfast, lunch and dinner for the skipper and crew, Friday evening through Sunday lunch.
- c. Registration and payment shall be made using Regatta Network. (<https://www.regattanetwork.com/event/24710>)
  - 4.c.i. Meals for guests along with T-shirt purchases are available at an additional cost using Regatta Network.

**5. SCHEDULE**

- a. Check-in and late registration will be available at PYC between 1200 -1700 hrs on Friday, September 30, 2022 and 0900 – 1000 hrs on Saturday, October 1, 2022.
- b. The scheduled time of the warning for the practice race is 1430 hrs on Friday, September 30, 2022.
- c. A competitors meeting will be held on October 1, 2022, at 1100 hrs.
- d. The warning signal for the first race on October 1, 2022, will be at 1330 hrs.
- e. The warning signal for the first race on October 2, 2022, will be at 1000 hrs.
- f. On the last scheduled day of racing no warning signal will be made after 1300 hrs. Up to 5 races are scheduled over the two days, no more than three races will be sailed on any one day.

## **6. VENUE**

- a. The event will be held in the waters of Perry Lake, directly east of the Perry Yacht Club. NoR Addendum A provides a map of Perry Lake.

## **7. COURSES**

- a. The courses to be sailed will be Class approved courses as published in the SCIRA Rulebook. Courses are shown in Addendum B.
  - 7.a.i. These courses may be modified in the sailing instructions

## **8. SCORING**

- a. One race is required to be completed to constitute a series.
- b. A boat's series score shall be the total of her race scores.

## **9. COMMUNICATION**

- a. Except in an emergency or when using equipment provided by the race committee, a boat that is racing shall not make voice or data transmissions and shall not receive voice or data communication that is not available to all boats.

## **10. RISK STATEMENT**

- a. Competitors participate in this regatta entirely at their own risk. See rule 3, Decision to Race. Competitors acknowledge that sailing involves potential risks. As a condition of their participation in this regatta, competitors release all claims they may have against the OA, Perry Yacht Club, SCIRA USA and its officers, directors, members, committees, and employees for damage to property, personal injury or death sustained in conjunction with or prior to, during or after the regatta. Competitors shall be responsible for damage or injury caused by their breach of the Racing Rules of Sailing or applicable governmental rules for the avoidance of collision.

## **11. Insurance**

- a. Each participating boat shall be insured with valid third-party liability insurance with a minimum coverage of \$300,000 per incident or the equivalent.

## **12. Prizes**

- a. The US Masters Championship Trophy will be awarded to the winner of the series.

- 12.a.i. Prizes will be awarded for skipper and crew for 5 places overall
- b. Additional awards will be given in the following age divisions of the skipper,
  - 12.b.i. Apprentice Master Division (45-54 years)
  - 12.b.ii. Master Division (55-64 years)
  - 12.b.iii. Grand Master Division (65-74 years)
  - 12.b.iv. Master Legends Division (75 years old and onwards).

**13. RIGHTS TO USE NAME AND LIKENESS**

- a. By participating in this event, competitors automatically grant to SCIRA, the OA and the event sponsors the right, in perpetuity, to make, use, and show, at their discretion, any photography, audio and video recording, and other reproductions of them made at the venue or on the water from the time of their arrival at the venue, until their final departure, without compensation.

**14. FURTHER INFORMATION**

- a. For additional information, please contact -

<b>Contact</b>	<b>Phone</b>	<b>Email</b>
Mary Buckley	402.432.6767	mary@buckley.biz
Doug Day	281.203.2103	Snipeskip@yahoo.com

## Addendum A. Lake Perry

The regatta will be sailed in the waters east of the Perry Yacht Club.

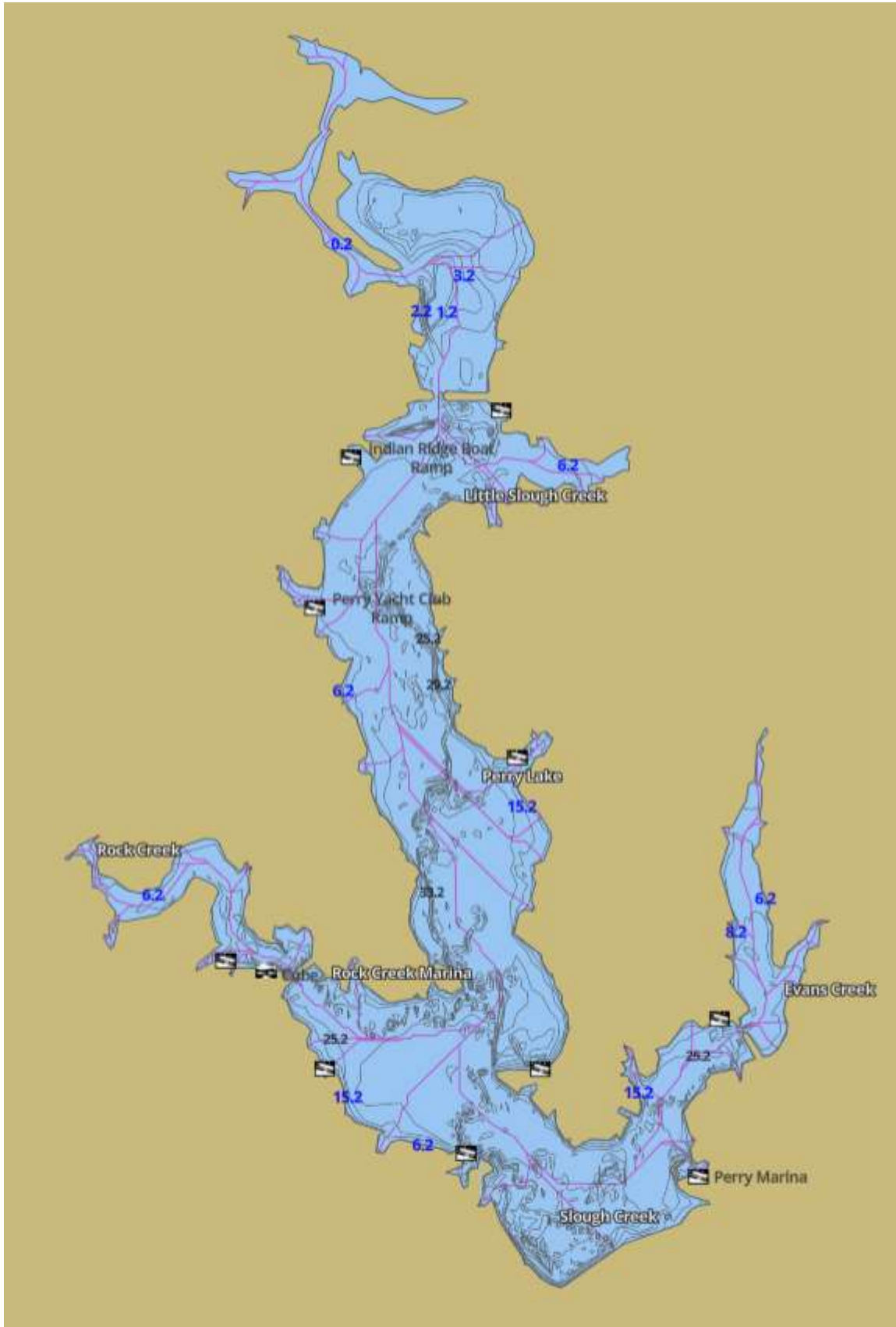

Addendum B. Courses

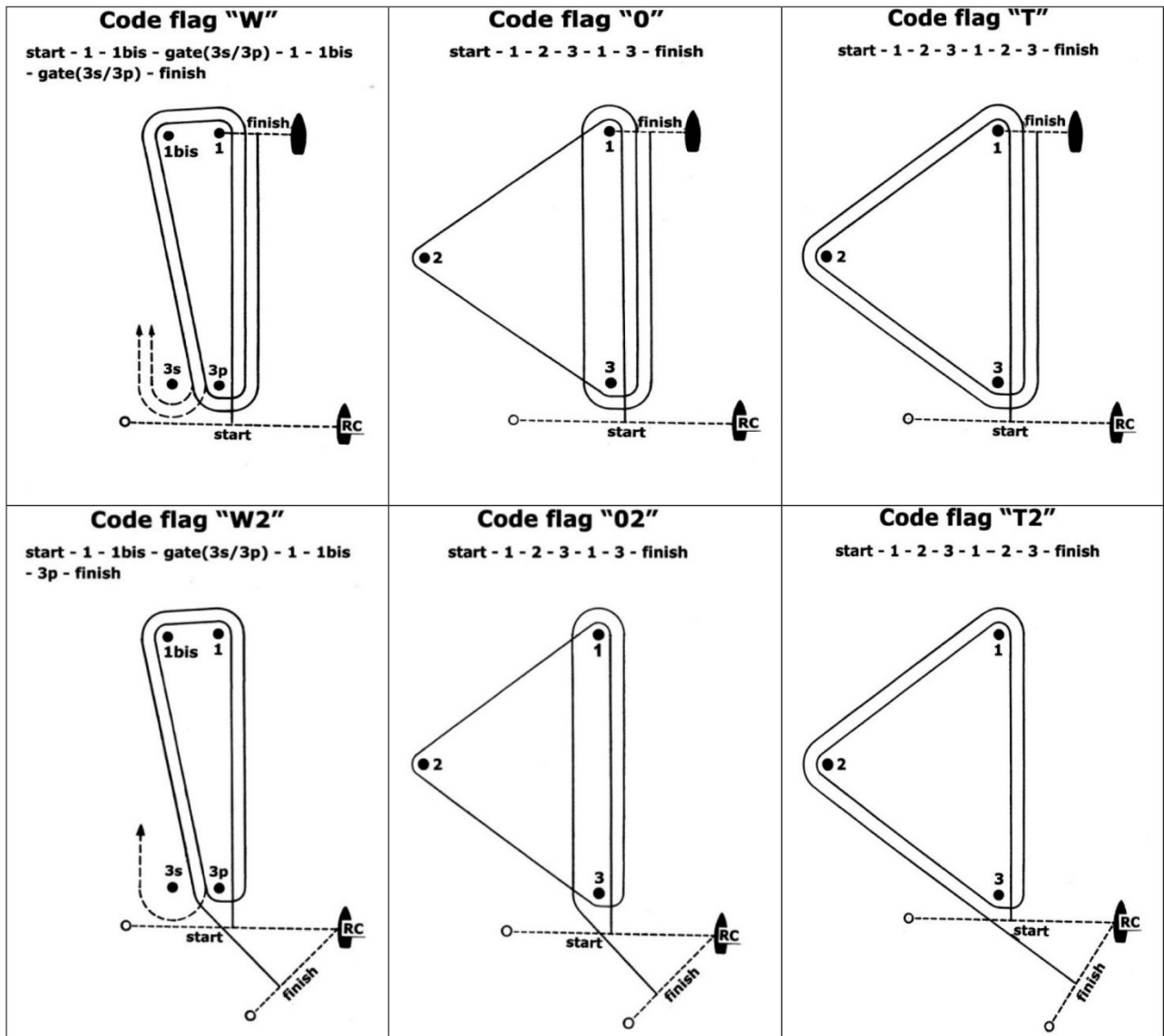

Code Flags will not be displayed. Course designations will be displayed on the White board placed on the starboard side of the signal vessel.

## **Additional Information NOT part of the NOR**

### **PERRY YACHT CLUB FACILITIES**

Showers and restrooms on the club grounds  
Covered (roofed) concrete pad with many picnic tables on the pad  
BBQ grills are beside the pad  
Refrigeration available in the club kitchen for medications

There are no hoists. Ramp launch only.

Park permit NOT required for entry to PYC.

(But watch your speed through the park section)

Phone landline in the kitchen at PYC: 785.484.2261

### **EMERGENCY**

Emergency: Dial 911

Be sure to tell dispatcher that location is Perry Yacht Club at the **NORTHWEST** corner of the lake.

### **HOUSING**

Nearest: Holiday Inn Express & Suites **NORTH** Topeka (approx 18 mi, 24 mins)  
601 NW US Hwy 24, Topeka, KS 66608  
877-859-5095

Tent camping available for free on the PYC grounds with beautiful sunrise and moon rise views.  
Away from city lights, star views are beautiful.

Camper spots w/ electrical hookups are available on site for free (first come basis)

VRBO and AirBNB availability is sparse and subject to change.

### **TRANSPORTATION**

Kansas City International Airport (MCI) is approximately a 90 min drive from PYC

### **CHARTER BOATS**

Some boats may be available for charter. Contact Mary Buckley 402.432.6767  
or [mary@buckley.biz](mailto:mary@buckley.biz)