

2022 Caryn Wilson Memorial Regatta

Tuesday, July 26, 2022

Hosted by Lavallette Yacht Club (OA)

SAILING INSTRUCTIONS

1. RULES:

- 1.1 The regatta will be governed by the rules as defined in the Racing Rules of Sailing (RRS) 2021 - 2024, these Sailing Instructions, and by the rules of the USODA.
- 1.2 The rules for all classes are altered so that membership in the class association is not required.
- 1.3 RRS 40 and RRS Part 4 preamble will be changed to require the wearing of a PFD at all times when afloat as outlined in Section 16 below
- 1.4 RRS 44.1 & 44.2 are changed so that the Two-Turns penalty is replaced by a One-Turn penalty
- 1.5 RRS A2.1 is changed to provide one discard with four (4) races as detailed in Section 15 below.
- 1.6 RRS 63.7 is replaced with; “ If there is a conflict between a rule in the notice of race and one in the sailing instructions, the sailing instructions shall apply.”

2. ELIGIBLE CLASSES:

Optimist Dinghy. The Optimist class will be divided into a Green Fleet and Championship Fleet. The Championship Fleet will be divided into Red, Blue, and White divisions based on the competitor's age on the day of the regatta. The Championship Fleet may be split into a White Fleet and a Blue/Red Fleet if necessary due to the number of registered boats.

3. NOTICES TO COMPETITORS

Notices to competitors will be posted on the official notice board located on the south porch of the Lavallette Yacht Club. Notices shall be considered as given to the competitors once they are posted on the notice board.

4. CHANGES TO SAILING INSTRUCTIONS

- 4.1 Any changes to the sailing instructions will be posted forty-five minutes before the first warning.
- 4.2 Oral instructions or advice by the Race Committee or official patrol boat personnel may be given on the water to clarify visual signals, or to promote safety.

5. SIGNALS MADE ASHORE

- 5.1 Signals made ashore will be displayed on the club's flagpole.
- 5.2 When flag AP is displayed ashore, '1 minute' is replaced with 'not less than 30 minutes' in race signal AP.

6. NUMBER OF RACES

Five (5) races are scheduled. The completion of one (1) race shall constitute the Regatta. No warning will be given after 3:30pm (1530).

7. SCHEDULE OF EVENTS

Arrival of boats

Boats should not arrive before 1PM, Monday, July 25th and must be parked such that the beach boat ramp is not blocked.

Tuesday, July 26, 2022

0800 – 0900 Check-in at clubhouse

0900 – 0930 Skipper's meeting

0930 Harbor gun

1000 First warning signal. Races to follow

Lunch break will be on land for Opti Green fleet.

Lunch break will be on the water for Opti Championship fleet.

No starting sequence will begin after 3:30 pm.

Awards to follow racing

8. RACING AREA

- 8.1. The sailing area is designated as south of Hankins Island, north of the West Point Island Flats, west of the Lavallette Town Dock and east of the Intracoastal Waterway.
- 8.2. Sailing Area A - Opti Green: Location to be advised at Competitor's meeting.
- 8.3. Sailing Area B - Opti Championship Fleet. Location to be advised at Competitor's meeting.

9. THE COURSES

Opti Green Fleet: Triangle - See Attachment 1

Opti Championship Fleet: Triangle/Windward – See Attachment 2

10. MARKS

- 10.1. Marks on the Opti Green course will be yellow or orange hippity hops.
- 10.2. Rounding Marks for the Opti Championship fleet will be yellow tetrahedrons. Start line mark will be an orange cylinder. Finish line mark will be an orange, red ball, or yellow ball to be announced at the skippers' meeting. Change of course mark will be an orange tetrahedron.

11. THE START

- 11.1. Races will be started by using RRS Appendix U, with an attention signal (a series of short sounds) at approximately 1 minute before the three minute warning signal.
- 11.2. The starting line will be between a staff displaying an orange flag on the committee boat at the starboard end and the starting mark at the port end
- 11.3. A boat starting later than three (3) minutes after her starting signal will be scored DNS (Did Not Start). This changes RRS A4.1.
- 11.4. The display of Code flag "I" at or before the warning signal of a race means the Round-an-End Rule is in effect as provided by RRS 30.1.
- 11.5. Individual Recalls will be made as provided by RRS U4.
- 11.6. All other race signals will be made as provided by RRS Race Signals.

12. THE FINISH

The finishing line will be between a staff displaying a blue flag on the finish boat at the starboard end and the finish mark at the port end.

13. TIME LIMIT

- 13.1. If no boat has passed the first mark within thirty (30) minutes, the race will be abandoned. If no boat has finished within sixty (60) minutes, the race will be abandoned. This changes RRS 35 and A4.1.
- 13.2. Boats failing to finish within fifteen (15) minutes after the first boat in a race sails the course and finishes will be scored Did Not Finish (DNF) without a hearing. This instruction changes RRS 35, A4, and A5

14. PROTESTS AND REQUESTS FOR REDRESS

- 14.1. A boat must inform a race committee finish boat immediately after finishing of its intention to protest another boat and provide the sail number of the protested boat. This changes RRS 61
- 14.2. Protest Forms are available at the Club in the registration area.
- 14.3. Protests and/or requests for redress must be filed with the race committee no later than thirty (30) minutes after the race committee boat docks. This changes RRS 61.3 & 62.2
- 14.4. Notices of protests by the race committee will be posted to inform boats under rule 61.1(b).
- 14.5. Notices will be posted within 30 minutes of the protest time limit to inform competitors of hearings in which they are parties or named as witnesses.

15. SCORING

- 15.1. The Low Point scoring system of RRS Appendix A as modified herein will apply.
- 15.2. When fewer than four (4) races have been completed, a boat's series score will be the total of all her race scores. This changes A2 of RRS Appendix A.
- 15.3. A DSQ, resultant from a failed safety equipment inspection, shall not be excluded for any reason regardless of the number of races completed. This changes RRS 90.3b.
- 15.4. No race shall be declared official unless three or more entrants come to the starting line.

16. SAFETY

- 17.1. USCG approved PFD must be worn zippered and with whistle attached at all times while afloat. This changes RRS 40 and RRS Part 4 preamble
- 17.2. A competitor retiring from a race shall notify a race committee boat or safety boat before leaving the course or notify the race committee immediately upon returning to shore.

18. DISCLAIMER OF LIABILITY

Competitors participate in the regatta entirely at their own risk. See RRS 4, Decision to Race. Lavallette Yacht Club will not accept any liability for material damage or personal injury or death sustained in conjunction with or prior to, during, or after the regatta.

19. PRIZES

Opti Green Fleet: Participation awards.

Opti Championship Fleet:

- Championship Fleet up to 10 deep Overall and up to 5 deep for Red, 10 deep for Blue, and 7 deep for White Fleets
- Lavallette Heritage Cup will be awarded to the top LYC boat.

ATTACHMENT 1: Opti Green

TRIANGLE

Start – 1 – 2 – 3 – Finish

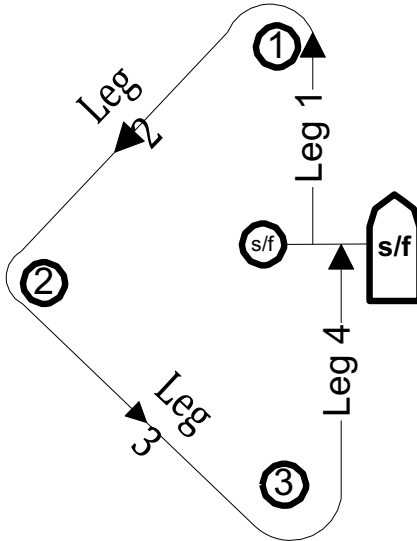

ATTACHMENT 2: Opti Championship Fleet

TRIANGLE/WINDWARD

Start – 1 – 2 – 3 – 1 – Finish

