



2022 SYC Thistle Regatta

Organizing Authority (OA): Savannah Yacht Club
September 24-25, 2022

SAILING INSTRUCTIONS

(version V3 09-19-2022)

The notation '[NP]' in a rule means that a boat may not protest another boat for breaking that rule. The notation '[DP]' in a rule means that the rule is subject to a discretionary penalty which can be less than disqualification.

1. RULES

The event is governed by the rules as defined in *The Racing Rules of Sailing* (RRS).

2. CHANGES TO SAILING INSTRUCTIONS

- 2.1 Any changes to the SIs made on shore will be posted before 0830 on the day it will take effect, except that any change to the schedule of races will be posted by 2000 on the day before it will take effect.
- 2.2 Oral changes to these SIs may be given on the water by hail from the RC Signal vessel in accordance with RRS 90.2(c). The RC Signal vessel will display code flag L with one sound and communicate the changes before the next warning signal.

3. COMMUNICATIONS WITH COMPETITORS

- 3.1 Notices to competitors will be posted on the official notice board located on the porch of the Dock House.
- 3.2 On the water, the race committee (RC) intends to monitor and communicate over VHF 71

4. [DP] CODE OF CONDUCT

Competitors and support persons shall comply with reasonable requests from race officials.

5. SIGNALS MADE ASHORE

- 5.1 Signals made ashore will be displayed from the SYC Mast on the Bluff of the Wilmington River.
- 5.2 When flag AP is displayed ashore, '1 minute' is replaced with 'not less than 45 minutes' in Race Signals AP.

6. SCHEDULE

<u>Friday, Sept. 23</u>	1400 – 1600 Club open for boat drop off in designated areas.	
<u>Saturday, Sept. 24</u>	0830	Coffee, Juice and Pastries
	0930 - 1030	Check in
	1030	Competitors Meeting
	1100	Harbor Start
	1200	First Warning Signal
	1800	Dinner SYC Dock House/Tent
<u>Sunday, Sept. 25</u>	0800	Coffee
	0900	Harbor Start
	1000	First warning signal
	1400	No warning signal will be made after this time
	After racing	Awards & wings at SYC Dock House

7. CLASS FLAGS

7.1 Class Flag will be Thistle class flag.

8. RACING AREA

NOR Attachment A shows the location of the host club and the Wilmington and Skidaway Rivers.

9. COURSES

9.1 The course will be displayed by course letter and/or number on the course board on the signal boat.

9.2 The courses are described in SI Attachment 1.

10. MARKS

10.1 Marks 1, 2 and 3 will be orange tetrahedrons.

10.2 Change marks as provided for in RRS 33 will be an green tetrahedrons.

10.3 The start mark will be a yellow tetrahedron or a race committee boat displaying an orange flag on a staff.

10.4 The finish mark will be an orange ball.

11. THE START

11.1 Races will be started using RRS 26.

11.2 The race Committee will make several sound signals shortly before any warning signal that is not at a scheduled time or is not preceded by the lowering of another signal.

11.3 Before the Warning Signal for the first race of each day, all competitors intending to race shall check in by sailing past the stern of the boat on starboard tack and hail their sail number. A boat that competes but fails to check in may at the discretion of the race committee receive a 20% scoring penalty. This modifies Rule 63.1 and A5.

11.4 The starting line is between staffs displaying orange flags on RC Signal Vessel and either a yellow tetrahedron or a staff displaying an orange flag on a RC Boat at the port end of the line.

11.5 [DP] Boats whose warning signal has not been made shall avoid the starting area during the starting sequence for other races.

11.6 A boat that does not meet the definition of *start* within five (5) minutes after her starting signal will be scored Did Not Start without a hearing. This is added to RRS A5.1 and A5.2.

12. CHANGE OF COURSE

After the start a change of course will be signaled in accordance with RRS 33.

13. THE FINISH

13.1 The finishing line is between a staff displaying a blue flag on the RC Signal Boat and the orange finishing ball.

14. PENALTY SYSTEM

14.1 RRS Appendix V shall apply.

14.2 Appendix P shall apply with "Two-Turns" replaced by "One-Turn", P2.1 is amended to delete "first" and P2.2 and P2.3 shall not apply.

15. TIME LIMITS

15.1 A boat that does not meet the definition of *start* within five (5) minutes after her starting signal will be scored Did Not Start without a hearing. This is added to RRS A5.1 and A5.2.

15.2 The time limit will be 90 minutes for the first boat to finish.

15.3 The finishing window is 15minutes after the first boat sails the course and finishes. Boats failing to finish within the finishing window, and not subsequently retiring, penalized, or given redress, will be scored Time Limit Expired (TLE) without a hearing. A boat scored TLE shall be scored points for the finishing place two more than the points scored by the last boat that finished within the finishing window but not worse than DNF. This is added to RRS 35, A5.1, A5.2 and A10. 16.4.

16 HEARING REQUESTS

16.1 Protest forms will be available at the Dock House near the official notice board.

16.2 The protest time limit is 30 minutes after the RC Signal vessel docks or the RC signals no more racing today, whichever is later. The time will be posted on the official notice board.

16.3 Notices will be posted no later than 30 minutes after the protest time limit to inform competitors of hearings in which they are parties or named as witnesses.

17. SCORING

17.1 The scoring system in RRS Appendix A4 will be used.

17.2 5 races are scheduled.

17.3 All races sailed will be scored.

17.4 One race is required to be completed to constitute a series.

18. [DP] [NP] SAFETY REGULATIONS

18.1 A boat that retires from a race shall notify a Race Official at the first reasonable opportunity or a SYC Staff Member promptly after returning to shore. A boat that withdraws from a race or does not intend to start a scheduled race shall inform a Race Official as soon as possible.

19. Any official or support vessel may assist any competitors in the case of an emergency. [DP] [NP] SUPPORT TEAMS

19.1 [DP] [NP] Coach vessels shall remain a minimum of 100 yards from the course area except when asked to assist by a race official. All coach and support vessels are required to monitor the course channel on a VHF radio and be ready to assist with safety when requested.

20. TRASH DISPOSAL

Trash and empty water bottles may be placed aboard support or race official vessels.

21. RISK STATEMENT

RRS 3 states: 'The responsibility for a boat's decision to participate in a race or to continue to race is hers alone.' By participating in this event each competitor agrees and acknowledges that sailing is a potentially dangerous activity with inherent risks. These risks include strong winds and rough seas, sudden changes in weather, failure of equipment, boat handling errors, poor seamanship by other boats, loss of balance on an unstable platform and fatigue resulting in increased risk of injury. **Inherent in the sport of sailing is the risk of permanent, catastrophic injury or death by drowning, trauma, hypothermia or other causes.**

22. FURTHER INFORMATION

Event Chair & Sailing Director: Adam Young, ayoungcms@yahoo.com, 205-960-6534 (text)

PRO, Martine Zurinkas, mar_rawlings@yahoo.com, 404-451-7743 (text)

Savannah Yacht Club, 912-897-1314

SI Attachment #1

Illustration A:

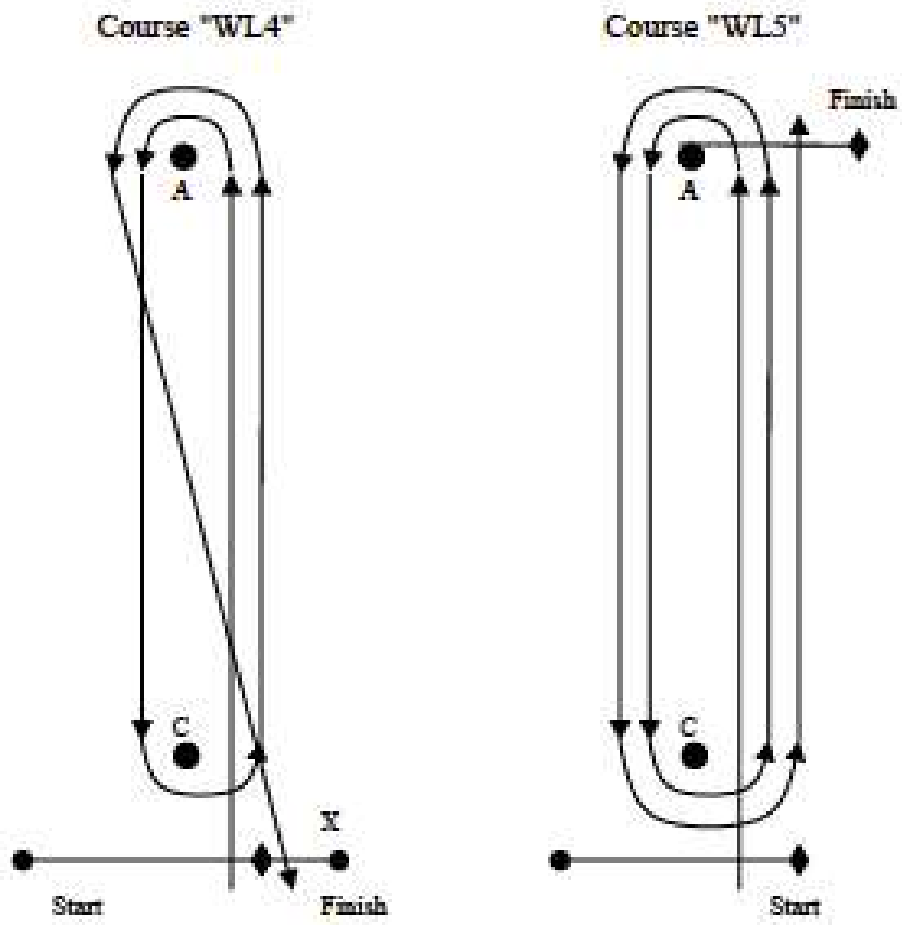



2022 SYC Thistle Regatta

Organizing Authority (OA): Savannah Yacht Club
September 24-25, 2022

SAILING INSTRUCTIONS

(version V3 09-19-2022)

The notation '[NP]' in a rule means that a boat may not protest another boat for breaking that rule. The notation '[DP]' in a rule means that the rule is subject to a discretionary penalty which can be less than disqualification.

1. RULES

The event is governed by the rules as defined in *The Racing Rules of Sailing* (RRS).

2. CHANGES TO SAILING INSTRUCTIONS

- 2.1 Any changes to the SIs made on shore will be posted before 0830 on the day it will take effect, except that any change to the schedule of races will be posted by 2000 on the day before it will take effect.
- 2.2 Oral changes to these SIs may be given on the water by hail from the RC Signal vessel in accordance with RRS 90.2(c). The RC Signal vessel will display code flag L with one sound and communicate the changes before the next warning signal.

3. COMMUNICATIONS WITH COMPETITORS

- 3.1 Notices to competitors will be posted on the official notice board located on the porch of the Dock House.
- 3.2 On the water, the race committee (RC) intends to monitor and communicate over VHF 71

4. [DP] CODE OF CONDUCT

Competitors and support persons shall comply with reasonable requests from race officials.

5. SIGNALS MADE ASHORE

- 5.1 Signals made ashore will be displayed from the SYC Mast on the Bluff of the Wilmington River.
- 5.2 When flag AP is displayed ashore, '1 minute' is replaced with 'not less than 45 minutes' in Race Signals AP.

6. SCHEDULE

<u>Friday, Sept. 23</u>	1400 – 1600 Club open for boat drop off in designated areas.	
<u>Saturday, Sept. 24</u>	0830	Coffee, Juice and Pastries
	0930 - 1030	Check in
	1030	Competitors Meeting
	1100	Harbor Start
	1200	First Warning Signal
	1800	Dinner SYC Dock House/Tent
<u>Sunday, Sept. 25</u>	0800	Coffee
	0900	Harbor Start
	1000	First warning signal
	1400	No warning signal will be made after this time
	After racing	Awards & wings at SYC Dock House

7. CLASS FLAGS

7.1 Class Flag will be Thistle class flag.

8. RACING AREA

NOR Attachment A shows the location of the host club and the Wilmington and Skidaway Rivers.

9. COURSES

9.1 The course will be displayed by course letter and/or number on the course board on the signal boat.

9.2 The courses are described in SI Attachment 1.

10. MARKS

10.1 Marks 1, 2 and 3 will be orange tetrahedrons.

10.2 Change marks as provided for in RRS 33 will be an green tetrahedrons.

10.3 The start mark will be a yellow tetrahedron or a race committee boat displaying an orange flag on a staff.

10.4 The finish mark will be an orange ball.

11. THE START

11.1 Races will be started using RRS 26.

11.2 The race Committee will make several sound signals shortly before any warning signal that is not at a scheduled time or is not preceded by the lowering of another signal.

11.3 Before the Warning Signal for the first race of each day, all competitors intending to race shall check in by sailing past the stern of the boat on starboard tack and hail their sail number. A boat that competes but fails to check in may at the discretion of the race committee receive a 20% scoring penalty. This modifies Rule 63.1 and A5.

11.4 The starting line is between staffs displaying orange flags on RC Signal Vessel and either a yellow tetrahedron or a staff displaying an orange flag on a RC Boat at the port end of the line.

11.5 [DP] Boats whose warning signal has not been made shall avoid the starting area during the starting sequence for other races.

11.6 A boat that does not meet the definition of *start* within five (5) minutes after her starting signal will be scored Did Not Start without a hearing. This is added to RRS A5.1 and A5.2.

12. CHANGE OF COURSE

After the start a change of course will be signaled in accordance with RRS 33.

13. THE FINISH

13.1 The finishing line is between a staff displaying a blue flag on the RC Signal Boat and the orange finishing ball.

14. PENALTY SYSTEM

14.1 RRS Appendix V shall apply.

14.2 Appendix P shall apply with "Two-Turns" replaced by "One-Turn", P2.1 is amended to delete "first" and P2.2 and P2.3 shall not apply.

15. TIME LIMITS

15.1 A boat that does not meet the definition of *start* within five (5) minutes after her starting signal will be scored Did Not Start without a hearing. This is added to RRS A5.1 and A5.2.

15.2 The time limit will be 90 minutes for the first boat to finish.

15.3 The finishing window is 15minutes after the first boat sails the course and finishes. Boats failing to finish within the finishing window, and not subsequently retiring, penalized, or given redress, will be scored Time Limit Expired (TLE) without a hearing. A boat scored TLE shall be scored points for the finishing place two more than the points scored by the last boat that finished within the finishing window but not worse than DNF. This is added to RRS 35, A5.1, A5.2 and A10. 16.4.

16 HEARING REQUESTS

16.1 Protest forms will be available at the Dock House near the official notice board.

16.2 The protest time limit is 30 minutes after the RC Signal vessel docks or the RC signals no more racing today, whichever is later. The time will be posted on the official notice board.

16.3 Notices will be posted no later than 30 minutes after the protest time limit to inform competitors of hearings in which they are parties or named as witnesses.

17. SCORING

17.1 The scoring system in RRS Appendix A4 will be used.

17.2 5 races are scheduled.

17.3 All races sailed will be scored.

17.4 One race is required to be completed to constitute a series.

18. [DP] [NP] SAFETY REGULATIONS

18.1 A boat that retires from a race shall notify a Race Official at the first reasonable opportunity or a SYC Staff Member promptly after returning to shore. A boat that withdraws from a race or does not intend to start a scheduled race shall inform a Race Official as soon as possible.

19. Any official or support vessel may assist any competitors in the case of an emergency. [DP] [NP] SUPPORT TEAMS

19.1 [DP] [NP] Coach vessels shall remain a minimum of 100 yards from the course area except when asked to assist by a race official. All coach and support vessels are required to monitor the course channel on a VHF radio and be ready to assist with safety when requested.

20. TRASH DISPOSAL

Trash and empty water bottles may be placed aboard support or race official vessels.

21. RISK STATEMENT

RRS 3 states: 'The responsibility for a boat's decision to participate in a race or to continue to race is hers alone.' By participating in this event each competitor agrees and acknowledges that sailing is a potentially dangerous activity with inherent risks. These risks include strong winds and rough seas, sudden changes in weather, failure of equipment, boat handling errors, poor seamanship by other boats, loss of balance on an unstable platform and fatigue resulting in increased risk of injury. **Inherent in the sport of sailing is the risk of permanent, catastrophic injury or death by drowning, trauma, hypothermia or other causes.**

22. FURTHER INFORMATION

Event Chair & Sailing Director: Adam Young, ayoungcms@yahoo.com, 205-960-6534 (text)

PRO, Martine Zurinkas, mar_rawlings@yahoo.com, 404-451-7743 (text)

Savannah Yacht Club, 912-897-1314

SI Attachment #1

Illustration A:

