

Appendix:

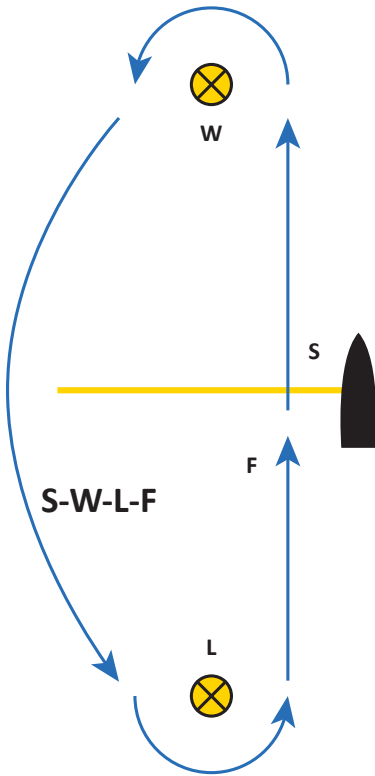

Course W – Windward / Leeward, Windward Finish	
Signal	Mark Rounding Order
W	Start – W – L – Finish
W2	Start – W – L – W – L – Finish

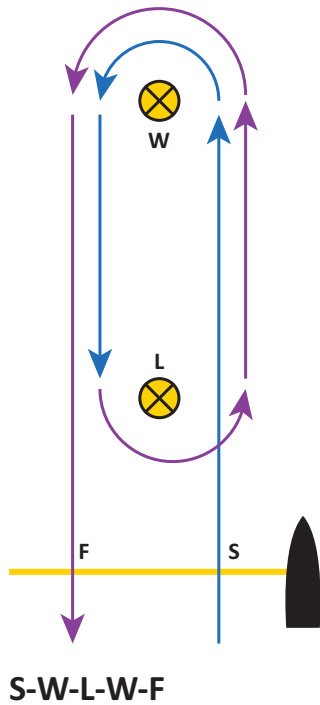

Course WL – Windward, Leeward Finish	
Signal	Mark Rounding Order
W	Start – W* – Finish
W2	Start – W* – L – W – Finish
Note: * - If an offset mark (1a) is present, sailors will leave the offset mark to Port after rounding the Windward Mark (1)	

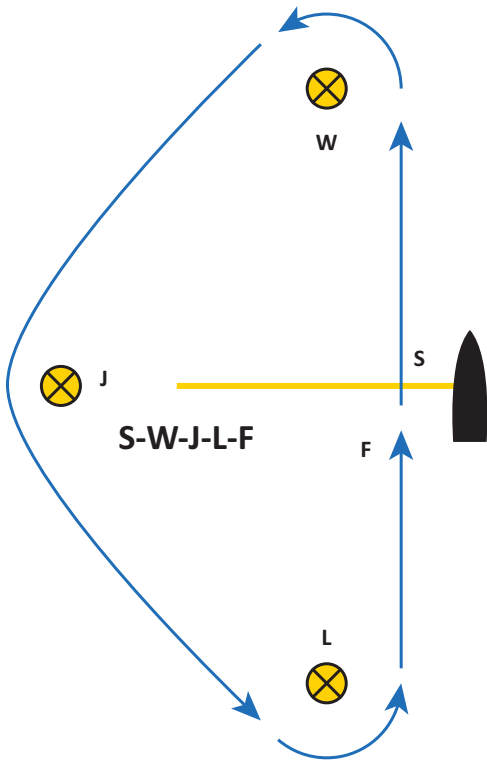

Course T – Triangle, Windward Finish	
Signal	Mark Rounding Order
T	Start – W – J – L – Finish
T2	Start – W – J – L – W – J – L – Finish

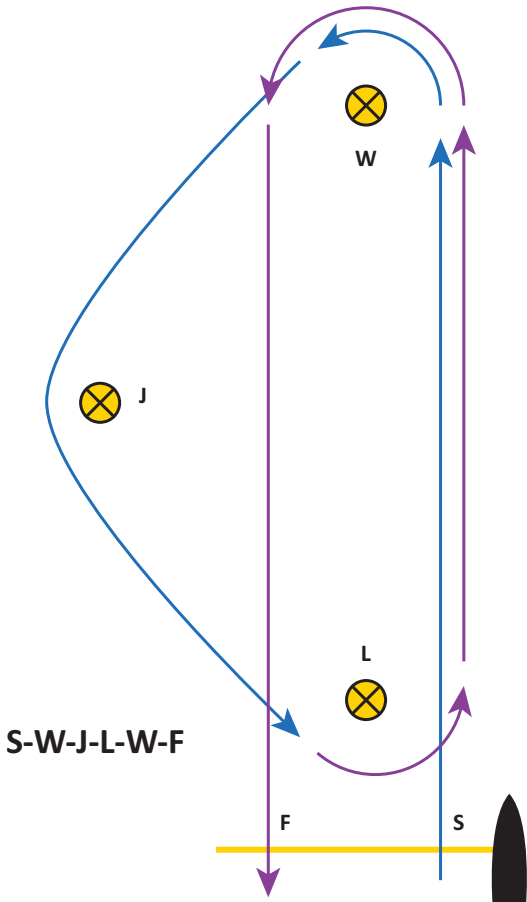

Course TL – Triangle, Leeward Finish	
Signal	Mark Rounding Order
TL	Start – W* – J – L – W – Finish
TL2	Start – W* – J – L – W – L – W – Finish
Note: * - If an offset mark (1a) is present, sailors will leave the offset mark to Port after rounding the Windward Mark (1)	

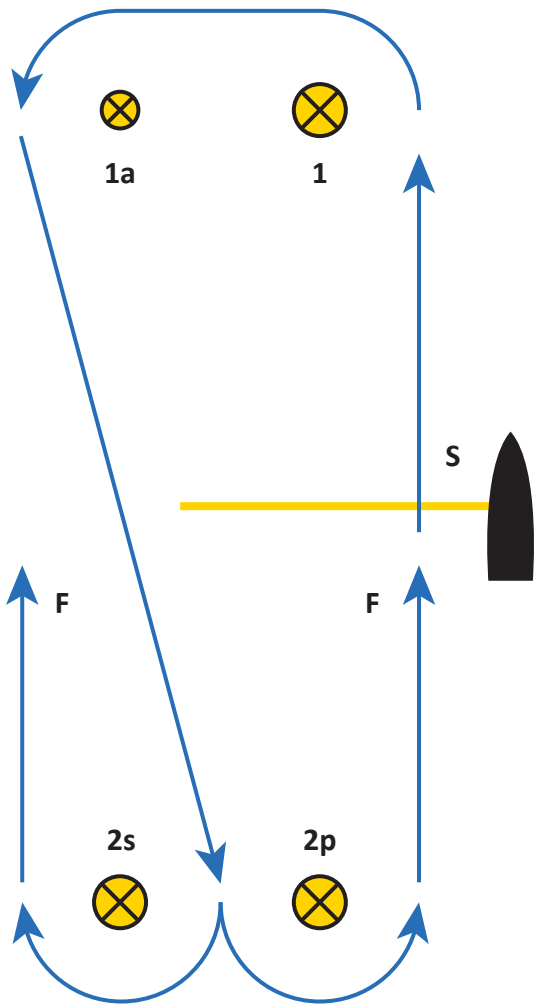

Course A – Windward / Leeward Gate, Windward Finish

Signal	Mark Rounding Order
A	Start – 1* – 2s / 2p – Finish
A2	Start – 1* – 2s / 2p – 1* – 2s / 2p – Finish

Note: * - If an offset mark (1a) is present, sailors will leave the offset mark to Port after rounding the Windward Mark (1)