



58th ANNUAL DON Q SNIPE REGATTA

APRIL 5-7, 2024

COCONUT GROVE SAILING CLUB
& SNIPE FLEET #7

SAILING INSTRUCTIONS

Posted April 2, 2024



1. RULES:

- 1.1. The event will be governed by the *rules* as defined in the current edition of the *Racing Rules of Sailing* (RRS), the current SCIRA Class Rules, By-Laws, and the Rules of Conduct for Sanctioned or Club/Fleet Regattas (ROC), the Notice of Race (NOR), and these Sailing Instructions (SI). The ROC are included as a race document on the Regatta Network event site.
- 1.2. The following US Sailing Prescriptions will apply: Appendix R and prescriptions to RRS 60.3, 61.4, 67, 70.5(a) and 76.1. The full text of these US Prescriptions will appear as a race document on the event website.
- 1.3. The following racing *rules* are being amended by these SI: RRS 27.1, 30.4, 32, 33, 35, 61, 62.2; Appendix A2, Appendix A5, Appendix A10; and Race Signals.
- 1.4. The following ROC are being amended by these SI: ROC 5 and 8.1.
- 1.5. In accordance with the SCIRA Advertising Prescription, this event shall comply with World Sailing Regulation 20.
- 1.6. Appendix P - Special Procedures for Rule 42, will not apply. However, P2.1 will apply for all penalties. P2.2 and P2.3 are deleted.
- 1.7. If there is a conflict between the NOR and the SI, the SI shall govern. This changes RRS 63.7.

2. NOTICE TO COMPETITORS:

- 2.1. All race documents, notices & results will be posted on the official notice board at Regatta Network, https://www.regattanetwork.com/event/26995#_newsroom. Failure of a boat to read any such postings will not be grounds for redress. This changes RRS 62.1(a).
- 2.2. On Thursday, April 4th at 1830, there will be a competitor's briefing at CGSC.
- 2.3. The Race Committee (RC) will be using VHF channel 73.

3. CHANGES TO SAILING INSTRUCTIONS:

- 3.1. Any change to the SI will be posted no later than 90 minutes before the next warning signal, except that any change to the schedule of races will be posted by 1900 hours on the day before it will take effect.
- 3.2. Any change or amendment to the SI shall have the prior approval of the PRO.
- 3.3. Oral changes to the SI may be given on the water. The RC signal boat shall display flag "L" and announce via megaphone in accordance with RRS 90.2(c). Competitors may also approach the signal boat and verbally receive the change or read it from a whiteboard while flag "L" is displayed.

4. SIGNALS MADE ASHORE:

- 4.1. Signals made ashore will be displayed at the CGSC flag hoist.
- 4.2. When flag AP is displayed ashore, "1 minute" is replaced with "not less than sixty (60) minutes" in the race signal AP. This changes RRS Race Signals.
- 4.3. In the event of an onshore postponement, the RC will communicate to competitors via WhatsApp, notifying competitors to check the on-line notice board. It is the responsibility of each entry to have at least one person signed up for WhatsApp notices.

5. SCHEDULE OF RACES:

- 5.1. The maximum number of races to be sailed is eight (8).
- 5.2. The maximum number of races that can be sailed on one day is three (3).
- 5.3. The first warning signal will sound at 1100 on Friday, Saturday and Sunday.
- 5.4. No warning signal will be made after 1430 on Sunday.

6. CLASS FLAG:

The Class Flag will be a white flag with the Snipe insignia/emblem.

7. RACING AREA:

The Racing Area will be on Biscayne Bay SE of Brennan Channel, just beyond Middle Ground Shoal and south of Dinner Key Channel.

8. COURSES & CONDITIONS:

- 8.1 The diagram in Attachment "A" shows the courses, the order in which the marks are to be passed, and the side on which each mark is to be left. The course length will be based on sailing conditions. This changes ROC 5.
- 8.2 No later than one minute before the warning signal, the RC signal boat will display the course to be sailed in yellow letters, on a black board, not signal flags. This changes RRS 27.1 and ROC 8.2.
- 8.3 The course board will be accompanied by one (1) sound signal when displayed and will remain displayed for four (4) minutes after the start. Timely removal of the course board shall not be grounds for redress. This adds to RRS 27.1.
- 8.4 The approximate compass bearing to Mark 1 will be displayed by a numerical posting on a board on the RC signal boat before the preparatory signal.
- 8.5 All marks must be left to port unless it is a gate or the "start/finish mark" when finishing.
- 8.6 **Mark 3 for course W and W2 will be a gate, 3 s/p. For course O, Mark 3 (for the second time rounding, for the final leg of the race) will be a gate, 3 s/p.**
- 8.7 No race will be started in less than a sustained 4 knots of wind. However, the RC may, in its discretion, decline to begin a race in less than a sustained 5 knots of wind. This changes ROC 9.1.
- 8.8 No race will be started in more than 23 knots of sustained wind, or in conditions where the winds are gusting to more than 27 knots. The RC may postpone any race if there are sustained winds over 18 knots.

9. MARKS:

- 9.1 Marks 1, 2 and 3 s/p will be orange tetrahedrons.
- 9.2 Any start or finish mark, if one is set, will be a green tetrahedron.
- 9.3 For the Windward/Leeward course(s) (course "W" or "W2"), an orange cylinder will be set as an offset mark approximately sixty feet to port of Mark 1.
- 9.4 The RC signal boat may set an inflatable buoy attached to its stern. The inflatable buoy and its attachment line are a limit mark and must be left to starboard when starting, and when finishing downwind it must be left to port.
- 9.5 For a change of course, new marks will be yellow tetrahedrons. If a subsequent change is needed, it will follow with the original mark.

10. THE START:

- 10.1 The starting line will be the course side of a line between a staff displaying an orange flag or shape on the RC boat at the starboard end and the port-end start/finish mark, or between staffs displaying orange flags on two RC boats.
- 10.2 All races will start in accordance with RRS 26.
- 10.3 No boat may start a race more than four (4) minutes after the starting signal for that race, and will be scored Did Not Start (DNS) without a hearing. This changes ROC 8.1, and RRS 35.
- 10.4 The starting line will be set downwind of Mark 3 (leeward mark or 3 s/p the gate). Mark 3 is not a mark of the course for the first leg of the race.
- 10.5 Six (6) minutes before the start, the RC will make multiple short sounds as an alert to the warning signal.

11. CHANGE OF COURSE OR NEXT LEG OF THE COURSE:

- 11.1 Shortening or lengthening the next leg of the course may not be by more than 30% of the original leg length. This changes RRS 33. Such changes will be signaled by the display of flag "C", a placard displaying + or -, and will be accompanied by repetitive sounds.
- 11.2 The number of legs of a course may not be reduced until after the second windward leg has been completed. This changes RRS 32. Such a change will be signaled by the display of flag "S", with two sound signals.
- 11.3 If the RC elects to change the course being sailed to a different designated course, such a change

will be signaled by the display of the appropriate flag and a course board with the new course description, accompanied by repetitive sounds before the lead boat rounds the mark at which such a change is signaled. This modifies RRS 33 and changes ROC 9.2.

- 11.4. Except at a gate, boats shall pass between the RC boat signaling the change and the nearby mark, leaving the mark to port and the RC boat to starboard.

12. THE FINISH:

- 12.1. For courses "W", "T", and "O", the finish line shall be the course side of a line between a staff displaying a blue flag on a RC boat at the starboard end and Mark 1 at the port end.
- 12.2. For courses "W2", "T2", and "O2", the finish line shall be the course side of a line between a staff displaying a blue flag or shape on the RC boat at the port end and the start/finish mark at the starboard end, or between staffs displaying blue flags on two RC boats.
- 12.3. The finish line for course T2 will be set square to the last reach leg, below the start line.
- 12.4. The finish line for courses W2 and O2 will be set at an angle below the start line.
- 12.5. The RC will display flag "A" while boats are finishing to indicate "No more racing for the day."

13. PENALTIES:

- 13.1. Any competitor taking a penalty in accordance with RRS 44.1 or 44.2 (*Penalties at the time of an incident*) is requested to notify the RC promptly upon finishing that race and to inform the RC of the identity of the other boat involved.
- 13.2. Any boat failing to check-in (CNF), in accordance with SI 18.1 and 18.2, will receive a scoring penalty. Points will be added to its finishing position equal to 10% of the starters in that race. This changes RRS Appendix A10.
- 13.3. The black flag may be used only in a fleet of 45 or more starters and only after two or more general recalls. This changes RRS 30.4.
- 13.4. A boat failing to finish a race will be scored DNF without a hearing and will be awarded points equal to one more than the number of boats finishing that race. This changes RRS A5.2.

14. TIME LIMIT:

- 14.1. The time limit for the first boat to finish shall be 65 minutes. Should the first boat fail to finish within the aforementioned time the RC shall abandon the race.
- 14.2. Should the first boat fail to complete the first lap within 30 minutes, the RC shall abandon the race. For the purpose of this Rule a lap shall mean the rounding of Mark 3, or 3 s/p (gate) for the first time.
- 14.3. Boats failing to finish within 15 minutes after the first boat sails the course and finishes will be scored DNF, and one (1) point more than the number of boats finishing within the time limit, without a hearing. This changes RRS Appendix A5.

15. PROTEST AND REQUEST FOR REDRESS:

- 15.1. A competitor's intent to protest shall be reported to the RC promptly upon finishing the race in which the incident occurred. This changes RRS 61. The protestor must still otherwise comply with RRS 61.
- 15.2. Protests must be filed within one (1) hour after the RC finish boat docking time or when a race is abandoned ashore. The protest time limit will be posted on the regatta website notice board.
- 15.3. Request for Redress filing time shall be no later than the protest time limit or 30 minutes after the incident or 30 minutes after the posting of penalty/decision, whichever is later. This changes RRS 62.2.

- 15.4. Scoring inquiries, **including potential redress requests relating to a starting penalty**, should be initiated by filling out the online Scoring Inquiry form at <https://docs.google.com/forms/d/e/1FAIpQLSc56x9WKwLpbLRiQE5NOPGtKmntlVJQTe6-IWplSqVouz5qlQ/viewform>. Alternatively, a completed Scoring Inquiry form may be photographed and emailed to ScoringInquiry@cgsc.org. Also, questions about the status of scoring inquiries can be emailed to ScoringInquiry@cgsc.org. The RC will investigate, get back to you, and attempt to resolve the issue. If the scoring inquiry turns into a redress request, then the redress time limit will have been satisfied if the Scoring Inquiry form was submitted before the redress time limit expired.
- 15.5. Protests and **requests for redress unrelated to a starting penalty** should be initiated by filling out the online Protest form at https://docs.google.com/forms/d/e/1FAIpQLSdzOkZE7vvK_iXfJzfTr2txULYBp3CoQjtoEphz2aVXlvU5lQ/viewform. Additionally, if a diagram is required, it should be photographed and emailed to Protest@cgsc.org. Alternatively, a completed Protest form may be photographed and emailed to Protest@cgsc.org. Also, questions about the status of protests and redress requests can be emailed to Protest@cgsc.org.
- 15.6. Protest notices and hearing schedules specifying the protesting and protested parties will be posted no later than one-half hour after the expiration of the protest filing time limit. It is each boat's sole responsibility to check the event website notice board or its e-mail promptly after the end of the protest filing time to see if she is cited in a protest. Representatives of boats who are parties to hearings and their witnesses shall remain on call until excused by the Protest Committee.
- 15.7. Protest hearings will be held in person at CGSC.
- 15.8. After a hearing, penalties for rules other than Part 2 or RRS 31 that do not specify a penalty may be at the discretion of the Protest Committee.

16. SCORING:

- 16.1. One (1) completed race will constitute a series for this event.
- 16.2. A boat's series score will be the total of her race scores. No race result will be excluded. This changes RRS Appendix A2.1.

17. SAFETY REGULATIONS:

- 17.1. Each day before the start of the first race, while flag "L" is displayed, each boat is required to sail on starboard tack past the stern of the RC signal boat and verbally check in. When the RC verbally acknowledges a boat's sail number, the check-in has been officially noted.
- 17.2. A boat that retires from a race shall notify the RC as soon as possible.

18. REPLACEMENT OF CREW:

- 18.1. The same crew shall race in all races.
- 18.2. Requests for the replacement of any member of the crew shall be submitted in writing to the PRO prior to 0900 on the day the change will take effect.
- 18.3. The request for replacement of any member of the crew requires the approval of the PRO.
- 18.4. Once a skipper and/or crew have been excused, they may not return for the balance of the series.
- 18.5. Co-skippers shall be allowed subject to the restrictions of SI 19.1 and 19.2.

19. EQUIPMENT AND MEASUREMENT CHECKS:

The RC may inspect competitors, or boats, at any time. Equipment inspections may be initiated at the finish of any race.

20. SUPPORT BOATS:

- 20.1. Coach vessels shall register with CGSC during Registration, receive a flag, and sign a credit card authorization. Upon request, a mooring ball will be assigned for overnight use. The vessel will be charged \$80 if the flag is not returned at the end of the regatta. No coach vessel will be allowed on the course without a flag.
- 20.2. No coach, other support or spectator vessels shall operate within 100 meters of the race course except to render assistance. Any competitor associated with personnel determined to have violated this rule shall be subject to protest and assessed a 20% penalty for the race in which the violation occurred.

20.3. Any coach, RC support boat, or spectator boat being operated singlehandedly in the immediate vicinity of, and associated with, this event shall have a kill switch lanyard attached to the operator as long as the engine is running.

21. DISCLAIMER OF LIABILITY:

Competitors participate in the event entirely at their own risk. See RRS Rule 3, Decision to Race and RRS 4, Acceptance of Rules. The Organizing Authority will not accept any liability for material damage or personal injury or death sustained in conjunction with or prior to, during or after the regatta. **By entering this regatta, you accept this condition.**

SI Addendum A – Courses

Notes:

- The course will be designated on a placard on the starboard side of the race committee signal vessel.
- At a leeward gate, if only one mark is set, then the mark shall be rounded to port.

Course W

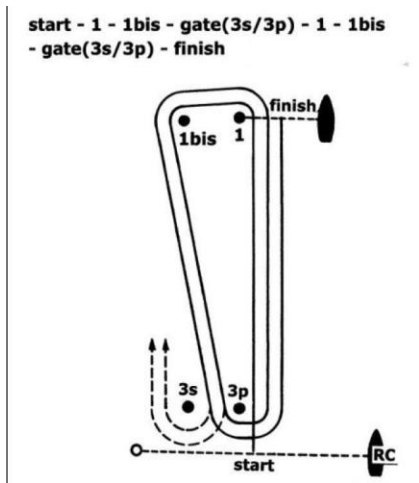

Course O

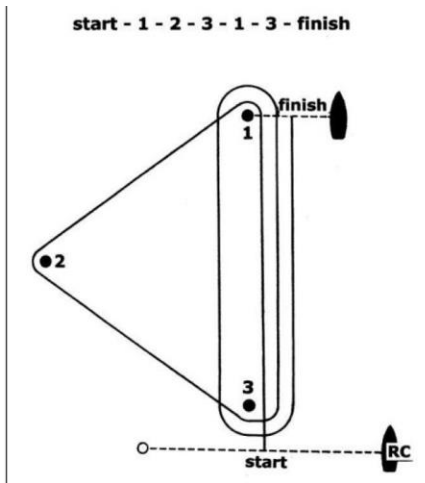

Course T

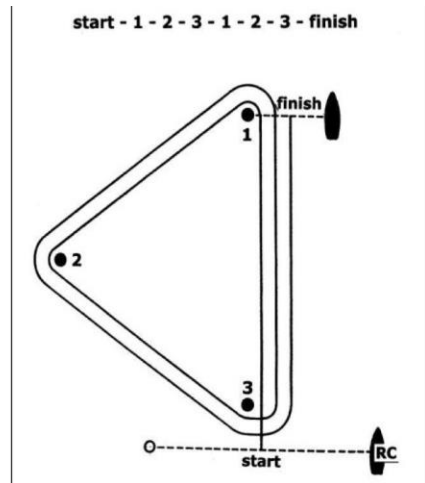

Course W2

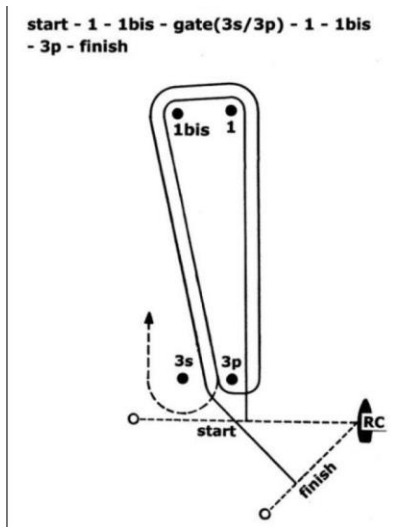

Course O2

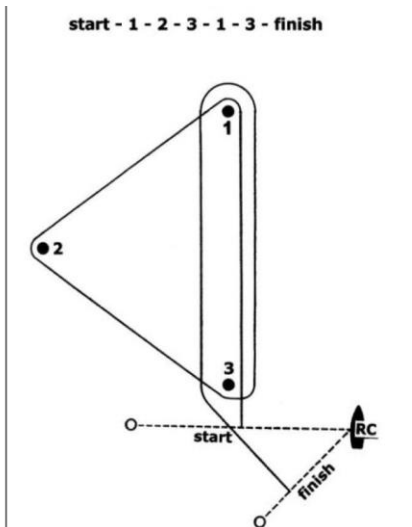

Course T2

