

# Midwinters

2023 Dec. 3 2024 Jan 7, Feb. 4, March 3

## Sailing Instructions - Addendum 2 Keller Cove Course - **Amendment 1,** **Amendment 2**



**RICHMOND  
YACHT CLUB**

### 1.0 COURSES & MARKS

- 1.1 Attachment A shows the order in which marks are to be passed, and the side on which each mark is left. Marks W, R & L are ~~red buckets or red balls~~ **orange or yellow inflatables** on the Keller Course.

### 2.0 STARTING

- 2.1 Per Rule 26 the starting sequence is changed to a 3 minute sequence with the warning signal given 3 minutes before the starting signal.

Signal Flags	Sound	Mins to Start
Warning	Horn Raise Fleet/Course Flag	3 min to start
Preparatory	Horn Raise P, I, or Z Flag	2 min to start
	Horn Lower P, I, or Z Flag	1 min to start
Start	Horn Drop Fleet Flag	Start

- 2.2 Prior to the first race of the day, each boat shall sail past the stern of the committee boat to hail her sail number for recognition.
- 2.3 Boats starting more than 10 minutes after their class starts will be scored DNS without a hearing.
- 2.4 The starting line will be between an orange flag on the committee boat and the starting mark (red bucket or red ball). See Attachment A.
- 2.5 For each fleet, the starting sequence for the next race will commence as soon as practical after the last boat of that fleet has finished. This may alter a previously announced starting order.
- 2.6 A boat whose warning signal has not been made shall avoid the starting area during the starting sequence for other fleets.

### 3.0 RESTRICTED AREAS

- 3.1 ~~The START and FINISH lines are restricted. A boat shall not cross the START line except when starting, preparing to start or cross the FINISH line except when finishing.~~  
After completing the first leg of the course, a boat shall not cross the starting line. A boat shall not cross the finishing line until she is completing the last leg of the course and finishes. A boat that breaks this rule shall not correct her error. However, she will be exonerated if she takes a Two-Turns Penalty (see rule 44.2). This changes rule 28.1. On a leg of the course from W to L or from L to W, boats may leave the line between S and F either to port or to starboard.
- 3.2 For reasons of safety, on legs of the course from W to L or from L to W, the starting and finishing lines and the buoys S and F are, taken together, one obstruction, and therefore rules 19 and 20 may apply between boats while they are approaching and passing it.

### 4.0 FINISHING

- 4.1 The finishing line will be between a blue flag on the committee boat and the finishing mark.

### 5.0 TIME LIMIT

- 5.1 The time limit for each fleet is 1.5 (one and a half) hours. Boats finishing more than 20 (twenty) minutes after the first boat in their fleet finishes will be scored as "Did Not Finish" without a hearing. This changes Rule 35.

# Midwinters

2023 Dec. 3 2024 Jan 7, Feb. 4, March 3

## Addendum A

### Keller Cove Courses



RICHMOND  
YACHT CLUB

**W** Weather Mark

**R** Reach Mark

**L** Leeward Mark

**S** Start Pin

**F** Finish Pin

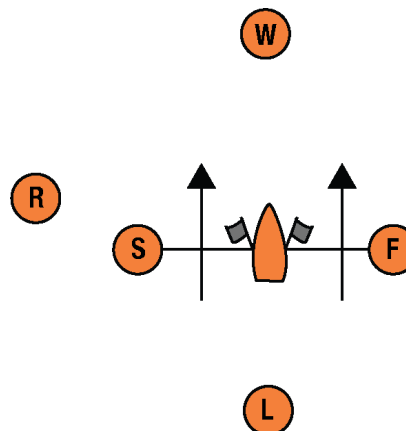

#### Courses (All marks rounded to port)

- |          |                                    |
|----------|------------------------------------|
| Course 1 | Start - W - L - Finish             |
| Course 2 | Start - W - R - L - Finish         |
| Course 3 | Start - W - L - W - L - Finish     |
| Course 4 | Start - W - R - L - W - L - Finish |