



SAILING INSTRUCTIONS

2013 Dr. DAVID OURSLER Star Spring Championship and Sport Boat Regatta

MILES RIVER YACHT CLUB

May 4 and 5, 2013

1. **RULES:** The regatta shall be governed by the rules as defined in *The Racing Rules of Sailing*.
2. **NOTICES TO COMPETITORS:** Notices to competitors shall be posted on the official notice board located in the entrance to the Club.
3. **CHANGES TO SAILING INSTRUCTIONS:** Any change to the sailing instructions or schedule of races shall be posted on the official notice board before 9:00 am.
4. **SCHEDULE OF EVENTS:**

	Saturday	Sunday
Registration	8:30 – 9:15 am	
Skippers' Meeting	9:15 am	
1 st Warning Signal	10:30 am	10:00 am
		No start after 2:00 pm
Awards		Approx. 3:00 pm

Note that there will be a delay between the Star start signals and the Sport Boat warning signals

Check the signal boat for a course board after each race to see if additional races are planned.

5. **CLASS FLAGS:** The class flag for Stars shall be the Star class flag. The class flag for Sport Boats will be the numeral pennant "1". Boats are not required to display a class flag.
6. **RACING AREAS:** The race area will be the Miles River south of Red #4 flasher (off Michaels), or in Eastern Bay near red N"8" as conditions warrant.
7. **THE COURSES:** The diagrams in "Appendix A" show the courses.
8. **MARKS:** The turning marks of the course shall be orange tetrahedron club drop marks. The starting pin shall be a yellow cylinder club drop mark.
9. **THE START:** The start line shall be between the orange/yellow flag on the signal boat and the adjacent yellow cylinder club mark as described in the course diagrams.
10. **THE FINISH:** The finishing line shall be between the orange/yellow flag on the signal boat and the adjacent yellow cylinder club mark as described in the course diagrams.

- 11. TIME LIMITS:** The time limit for any one race is 120 minutes. RRS 35, A4 and A5 is changed to provide that boats finishing more than 60 minutes after the first boat to finish will be scored "Did Not Finish" without a hearing.
- 12. PROTESTS:** All protests and requests for redress must be submitted to the Race Committee at the end of each day within 60 minutes of the Race Committee docking at the Club. Notices of protests shall be posted no later than 30 minutes after the protest time limit.
- 13. SCORING:** The low point scoring system of RRS Appendix A shall apply. One completed race constitutes a series. Each boat's series score shall be the total of her race scores unless five (5) or more races are completed and then she may exclude her worst score.
- 14. PRIZES:** Star trophies will be awarded to 1st, 2nd, and 3rd place finishers. Stars will also be competing for the overall series Dr. David Oursler Trophy. Sport Boats will be awarded trophies depending on the number of entries.

The awards ceremony is scheduled for approximately 3:00 pm on Sunday.

- 15. DISCLAIMER OF LIABILITY:** Competitors participate in the regatta entirely at their own risk. See rule 4, Decision to Race. The Miles River Yacht Club will not accept any liability for material damage or personal injury or death sustained in conjunction with or prior to, during, or after the regatta.

APPENDIX A: COURSE DIAGRAMS

COURSE A

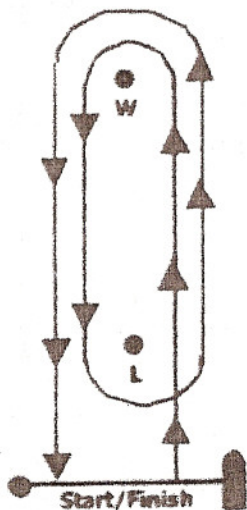

COURSE B

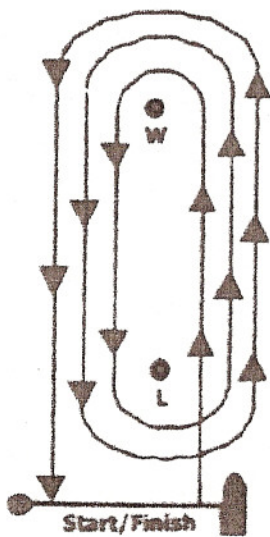

COURSE C

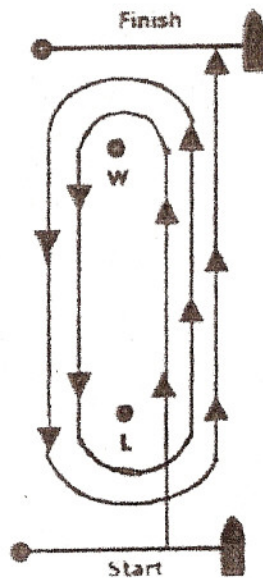

COURSE T

(Start - 1 - 2 - 3 - 1 - 2 - 3 - Finish)

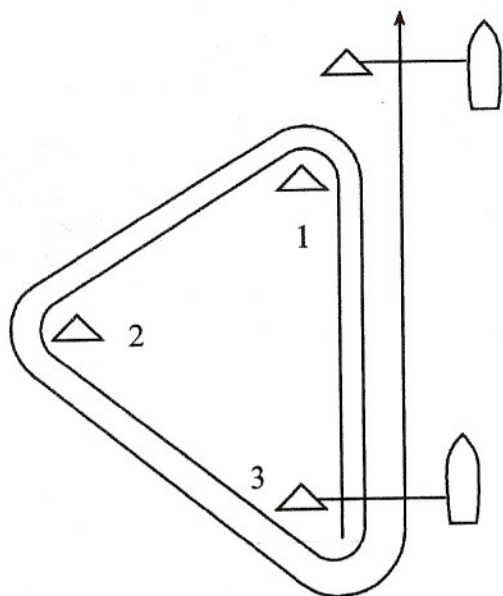

COURSE M

(Start - 1 - 2 - 3 - 1 - 3 - Finish)

