



# SARASOTA SAILFEST SAILING INSTRUCTIONS 2014

The Sarasota Sailfest Regatta will be held on April 5 and 6, 2014 at the Sarasota Sailing Squadron (SSS) located at 1717 Ken Thompson Parkway, Sarasota, FL. The organizing authority is Sarasota Youth Sailing Program.

## 1. RULES

1.1 The regatta will be governed by the rules as defined in the Racing Rules of Sailing (RRS) 2013-2016, the prescriptions of USSA, the applicable class rules, the Notice of Race, except as any of those that are changed by these Sailing Instructions. If there is any conflict between these Sailing Instructions and the Notice of Race, these Sailing Instructions will take precedence.

1.2 Competitors shall not discharge rubbish into the water.

## 2. ELIGIBILITY AND ENTRY

2.1 All competitors must meet the eligibility requirements as stated in the Notice of Race and have filed valid entries in accordance with the Notice of Race.

## 3. NOTICES TO COMPETITORS

3.1 Notice to competitors will be posted on the notice board located at the east end of the pavilion.

## 4. CHANGES IN THE SAILING INSTRUCTIONS

4.1 Any change to the sailing instructions will be posted no later than 90 minutes before the first scheduled warning signal on that day, except that any change to the schedule of races will be posted by 2000 on the day before it will take effect.

## 5. SIGNALS MADE ASHORE

5.1 Signals made ashore will be displayed at the flagpole on the clubhouse lawn. Code Flag "AP" Answering Pennant; with two sound signals (one when lowered) means races are postponed on a particular course but not necessarily all courses. Check official notice board to see which courses are being postponed. The warning signal will be made not less than 30 minutes after "AP" is lowered.

## 6. SCHEDULE OF EVENTS

### Friday, April 4

1700-2000 Check-In and Late Registration

### Saturday, April 5

0800-0900 Check-In and Late Registration

0930 Competitors' Briefing

1100 First Signal for All classes except Optimist Green

1115 First signal for Optimist Green

After Racing Dinner

Sunday April 6

0930 First Signal for All classes

1400 No Warning Signals after this time

ASAP after racing: Awards

*Lunch will be passed out before departing for the race course.*

**7 CLASS FLAGS**

7.1 Class flag descriptions will be posted on the Official Notice Board for each individual course.

**8 RACING AREA AND COURSES**

8.1 The racing area will be in Sarasota Bay and will be posted on the official bulletin board prior to 0930 hrs Saturday.

8.2 The diagrams in attachment 1 show the courses. Please check the Notice Board for updated course information for each course which may include offsets and/or leeward gates.

8.3 Competitors who have finished shall stay well clear of competitors that are still racing. Failure to comply with this instruction may result in a penalty up to and including disqualification from the races sailed on the particular day.

8.4 The start and finish lines are restricted except when starting, finishing, or rounding a designated rounding mark in a prescribed course in order to complete that course. Any boat infringing the above shall be scored "DNS."

**9 MARKS**

9.1 Mark Descriptions will be posted on the official Notice Board for each individual course.

**10 CHECK-IN**

10.1 Before the warning signal of the first race of each day, each boat shall sail past the stern of the race committee signal boat on starboard tack and hail her sail number, which will be acknowledged by the race committee. Any boat failing to do so will be scored as a DNS. Additionally, all Optimist sailors must check-out and in on shore.

**11 THE START**

11.1 Races will be started in accordance with RRS 26

11.2 The starting line and finish line will be between a staff displaying the orange flag on the Race Committee Signal Boat

11.3 Boats whose warning signal has not been made shall remain clear of the starting area. Only yachts whose class flag is flying may come within 200 feet of the starting committee boat or the starting line. Failure to do so may result in disqualification for that race.

11.4 A boat shall not start later than five (5) minutes after her starting signal. Such boat will be scored DNS

## **12 RECALLS**

- 12.1 Recalls will be signaled in accordance with RRS 29.1 and RRS 29.2
- 12.2 The following shall not be grounds for redress: failure of the race committee to hail one or more boats, failure of a competitor to hear the hail, timeliness of the hail, and the order in which boats are hailed.

## **13 CHANGE OF COURSE AFTER THE START**

- 13.1 When changing the course after the start, the Race Committee will lay a new mark and might not lift the original mark. If a change mark description is not posted on the official notice board prior to 0900 Saturday for the course in question, the change mark will be the original mark type.

## **14 TIME LIMITS**

- 14.1 Boats finishing more than 30 minutes after the first boat in her start will be scored DNF. This changes RRS 35.

## **15 ABANDONMENT**

- 15.1 RRS 32.1(e) is modified to read "for any other reason directly affecting the safety or fairness of the competition, or, when in the Race Committee's judgment, the race is an unsatisfactory test of skill."

## **16 OPTIMIST GREEN FLEET**

- 16.1 Green Fleet is open to skippers who meet all of the USODA Definition of Green Fleet.
- 16.2 Coaching of Green Fleet skippers while racing is permitted; however coaching shall be limited to skippers in the bottom half of the fleet in any given race. Coach boats shall neither create wakes nor otherwise interfere with competitors. Violation of this instruction may result in any penalty, which the jury deems appropriate, up to, and including the disqualification of the coached skipper from the regatta.

## **17 SUPPORT BOATS**

- 17.1 While racing, coach, support and spectator boats shall stay outside the course area from the Preparatory signal until all boats have finished or withdrawn, except as described in section 16, Optimist Green Fleet.
- 17.2 After the finish, coach and support boats shall not communicate with competitors until they are well clear of the finish
- 17.3 Violation of any of SI 17 may result in a penalty up to and including disqualification of the competitor or competitors associated with the craft violating this instruction for the race in which the violation occurs.
- 18.1 Competitors intending to protest shall inform the Race Committee immediately after finishing and before communicating with coaches or spectators. Boats should first sail to the non-course side of the Finish Boat and report to the Finish Boat. Boats that do not finish shall report their intent to protest to any Race Committee Boat at the first possible opportunity.
- 18.2 Protest forms will be available at the SSS office and must be lodged there within 30 minutes after the time the Race Committee Finish Boat docks. Docking time for Race Committee Finish Boat shall be posted for each course on the official notice board.

18.3 The Protest Committee will hear protests as soon as practical after they have been filed. The schedule of hearings will be posted on the official notice board shortly after the time limit for filing.

18.4 63.3 is changed such that a boat that is a party to a protest may be represented only by its helmsman.

## 19 SCORING

19.1 One race constitutes a regatta.

If five (5) or more races are completed, a boat's worst score shall be excluded when calculating her total score. This changes RRS A2.

20.1 Each competitor shall follow all instructions given by a designated safety boat.

20.2 All competitors sailing lasers, optimists (on all courses), 420s and multi hulls are required to wear a USCG approved lifejacket (PFD) from the time the competitor leaves the shore until he/she returns to the shore. A safety whistle, to be used for emergency purposes only, shall be attached to the life jacket.

20.3 A boat that retires from a race shall notify the race committee as soon as possible.

20.4 Competitors who require assistance should so signify by blowing a whistle or waving one arm. The RC reserves the right to assist competitors who, in the opinion of the Committee, require assistance, regardless of the wishes of the competitor.

## 21 PRIZES

21.1 Trophies will be given to the top three (3) finishers in each fleet

21.2 All participants in Green Fleet will receive a participation award.

# ATTACHMENT 1

## COURSE DIAGRAMS

OFFSET MARKS AND/OR  
LEEWARD  
GATES MAY BE USED  
WITH W1 AND W2  
COURSES, PLEASE  
REFER TO THE  
NOTICE BOARD

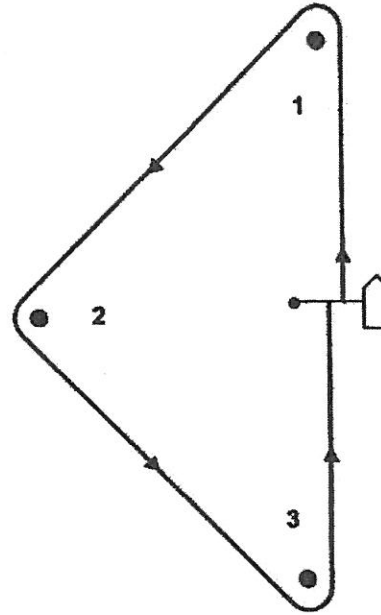
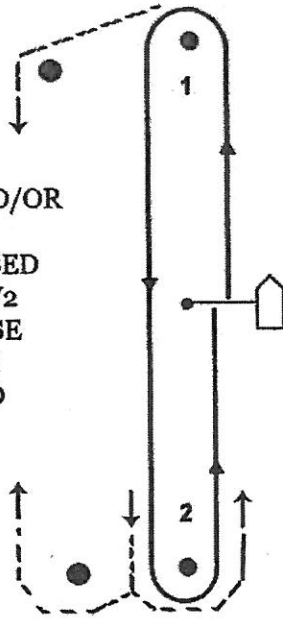

A TRIANGLE  
WILL BE USED  
FOR GREEN FLEET

Modified Windward-Leeward (W1)  
START-1-2-FINISH

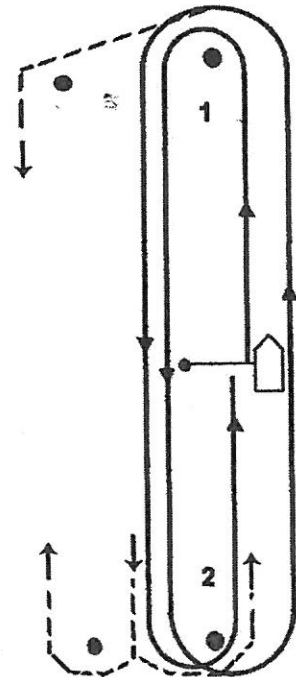

Modified Windward-Leeward Twice  
Around (W2)

Modified Triangle (T)  
START-1-2-3-FINISH

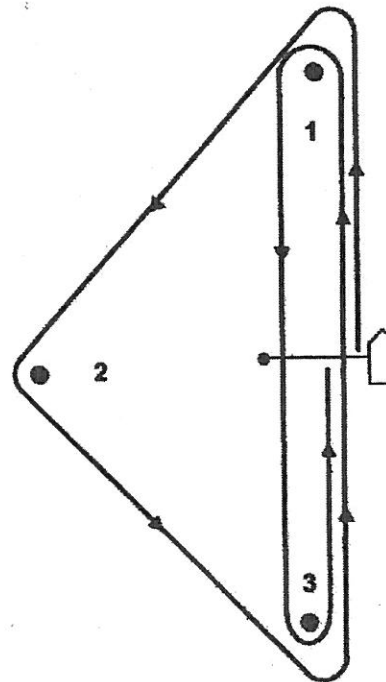

Modified Olympic (O)  
START 1-2-3-1-3-FINISH