

South Jersey Summer Series CYCCM Midsummer Regatta

July 17, 2014

Sailing Instructions

1. RULES

This regatta will be governed by the rules as defined in the Racing Rules of Sailing 2013-2016, South Jersey Summer Series Rules and Regulations, Notice of Race, and these Sailing Instructions.

2. NOTICE TO COMPETITORS

Notice to competitors will be posted on the Official Regatta Notice Board located in Club behind the Registration Table.

3. CHANGES TO SAILING INSTRUCTIONS

Any change to these sailing instructions will be posted on the Official Regatta Notice Board not later than 1200 on the day of the regatta.

4. SIGNALS MADE AFLOAT

In accordance with RRS 90.2 (c), oral changes to the Sailing Instructions may be made on the water. A change is in effect when the Race Committee boat displays code flag L over A with one sound signal. This means come within hail of the Race Committee boat to receive the oral change to the Sailing Instructions.

5. SCHEDULE OF RACES

5.1 The goal is to sail five races for the regatta. The Race Committee reserves the right to have more or less races.

5.2 The scheduled time for the warning signal for the first race is 1200.

6. SAILING AREAS

6.1 Sailing areas will be described at the Competitors' Meeting.

6.1.1 Optimist RBW Fleet will sail across the channel to the other side of the Harbor

6.1.2 Laser Radial and 420 fleets will sail west of the club in the "Cove" area of the Harbor.

6.1.3 Green Fleet Optimist Fleet will sail in front of, or next to, the Club.

6.2 The Race Committee of each fleet reserves the right to change the sailing area depending on wind or weather conditions.

7. CHECK-IN

7.1 Before the warning signal of the first race, each contestant shall sail past the stern of the fleet's Race Committee Signal boat and hail her sail number until acknowledged by the Race Committee (by repeating the yacht's number). **A yacht failing to do so will be scored DNS for all races until such time as the contestant complies with this section.**

8. COURSES

8.1 The course will be selected from the attached course description. This illustration shows the course, and the order in which the marks are to be rounded.

8.2 The course will be posted on the starboard side of the Race Committee boat and will be hailed to the competitors before the start of each race. It is the responsibility of the contestants to check the course before the start of each race.

9. MARKS

9.1 Marks for the Optimist RBW Fleet will be yellow tetrahedrons.

9.2 Marks for the Laser Radial/420 Fleet will be orange tetrahedrons.

9.3 Marks for the Optimist Green Fleet will be round, orange balls.

10. START

- 10.1 Races will start using RRS 26 sequence. Signals will be made at 5 minutes, 4 minutes, 1 minute, and at the start. **Only** the Optimist Green fleet will use a “Dinghy Starting Sequence”.
- 10.2 RRS 30.3 “Black Flag” will not be used.
- 10.3 The starting line will be between a staff with an orange flag displayed on the Race Committee boat at the starboard end of the line and a round, orange ball on the port end.
- 10.4 The “I Flag” (One-Minute Rule) may be used at the discretion of the Race Committee.
- 10.5 Contestants that are over early will be hailed by the Race Committee, but it is solely the responsibility of the contestant on the course side (OCS) at the start to properly return and restart the race.

11. TIME LIMIT

Boats that finish 15 minutes after the first finisher will be scored DNF.

12. FINISH

The finish line will be between a staff displaying an orange flag on the Race Committee boat and a round, orange ball.

13. PENALTIES

RRS Rules 44.1 and 44.2 apply for all fleets.

14. PROTESTS

- 14.1 A boat intending to protest shall report her intentions to the person being protested and the boats being protested to the Race Committee upon finishing or retiring. The protesting boat must obtain Race Committee acknowledgement of their protest. **This changes RRS 61.1 (a).**
- 14.2 Written protest on US Sailing Protest Forms are provided at the Official Regatta Notice Board shall be lodged with the Principal Race Officer within 30 minutes of the docking time of the Race Committee boat after the final race of the day. The docking time will be posted on the Official Regatta Notice Board.
- 14.3 Protests will be heard in the order of receipt. Order of the protests will be posted on the Official Regatta Notice Board identifying protesting and protested boats. It is the responsibility of each boat to check the schedule and attend the hearing in a timely manner with all parties and witnesses in order. The Protest Committee is not responsible for searching for parties or their witnesses.

15. SAFETY

- 15.1 A boat intending to withdraw from racing shall attempt to notify the Race Committee of her withdrawal before leaving the race area, and if not successful, **shall notify the PRO via cell phone at 610.405.5419** as quickly as possible.
- 15.2 **Every contestant must properly wear a PFD throughout the racing series.** Contestants will be notified of violations by the race committee and if the violation is not immediately corrected, the boat upon with the contestant is sailing will be scored DNS or DNF as the individual incident may call for.

16. SCORING

- 16.1 If six or more races are completed, each boat’s worst score shall be discarded, unless the score is the result of a violation of paragraphs 15.2 (Proper Wearing of PFD) or RRS 2 (Fair Sailing) in which case the next worse score shall be discarded, otherwise, a boat’s series score shall be the total of her race scores.
- 16.2 One race shall constitute a regatta.

CYCCM Midsummer Regatta Courses

"T4"

Order: Start – 1 – 2 – 3 – Finish

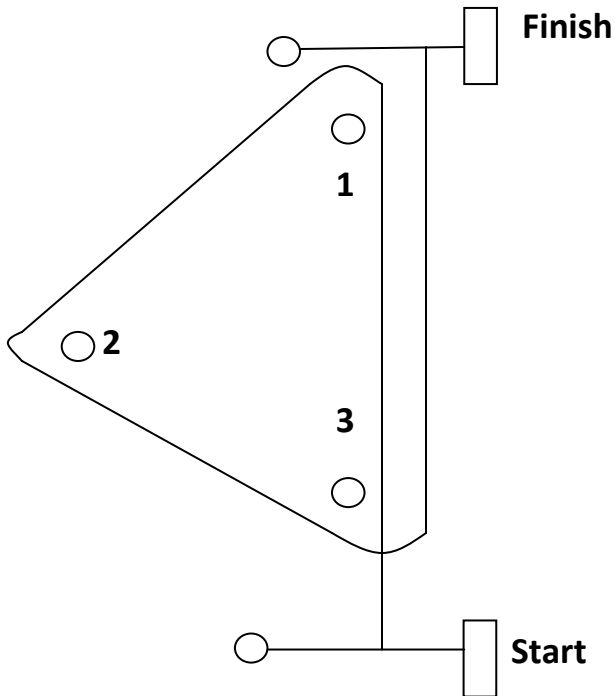

"O"

Order: Start – 1 – 2 – 3 – 1 – 3 - Finish

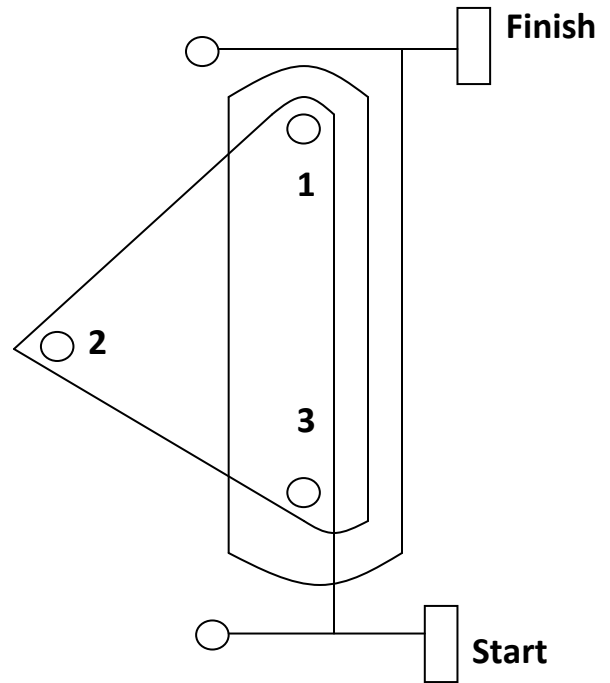

"W3"

Order: Start – 1 – 2 – Finish

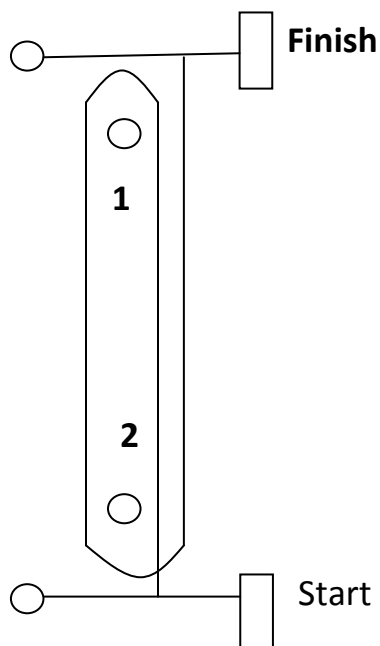

"W5"

Order: Start – 1 – 2 – 1 – 2 – Finish

