

**Blackbeard
One-Design Regatta**



**August 23th & 24th, 2014
Blackbeard Sailing Club
New Bern, North Carolina**

Sailing Instructions

1 RULES

1.1 The regatta will be governed by the rules as defined in *The Racing Rules of Sailing* and the various class rules.

1.2 Penalties at the time of an incident.

The first to sentences of rule 44.1 are changed to: " A boat may make a One-Turn Penalty when she may have broken a rule of Part2 or rule 31 while racing. However, when she may have broken a rule of Part 2 while in the zone around a mark other than a starting mark, her penalty shall be a Two-Turns Penalty."

2 ORGANIZING AUTHORITY

2.1 Blackbeard Sailing Club is the Organizing Authority.

3 NOTICES TO COMPETITORS

3.1 Shall be posted on the official bulletin board; (glass panels on the clubhouse deck).

4 CHANGES TO SAILING INSTRUCTIONS

4.1 Any changes to sailing instructions shall be posted before 0900 on the day it will take effect and announced at the Skippers Meeting, except that any change to the schedule of races will be posted by 2000 on the day before it will take effect.

5 SIGNALS MADE ASHORE

5.1 Signals made ashore will be displayed on the flagpole at the BSC clubhouse deck.

5.2 Signal Flag AP with one sound means "The warning signal will be made not less than 45 minutes after flag AP is displayed. Boats are requested not to leave the harbor until this signal is made. This changes race signal AP.

6 SCHEDULE OF RACES

All fleets except Optimist

6.1 Saturday August 23rd 09:00 Skippers Meeting on the BSC Clubhouse deck
10:55 First Class Warning Signal. Other races to follow.

6.2 Sunday, August 24th 09:55 First Class Warning Signal. Other races to follow. No starts after 12:30.
14:00 (SHARP) Awards Ceremony at the Blackbeard Clubhouse

7 CLASSES AND CLASS FLAGS

7.1 Class flags will be assigned at the skippers meeting and posted on the official bulletin board.

7.2 Four One-Design boats shall make a one-design class. Less than four boats of a design shall compete in the Open Class by Portsmouth Yardstick scoring together with other designs.

8 RACING AREAS

8.1 Race courses will be located on the Neuse River and/or Upper Broad Creek.

9 The Courses

- 9.1 The diagrams below show the courses, including the approximate angle between legs, the order in which the marks are to be passed, and the side on which each mark is to be left.
- 9.2 No later than the warning signal, the RC signal boat will post the course to be sailed and the number of laps will be displayed from the stern of the Signal boat by black writing on a white background.

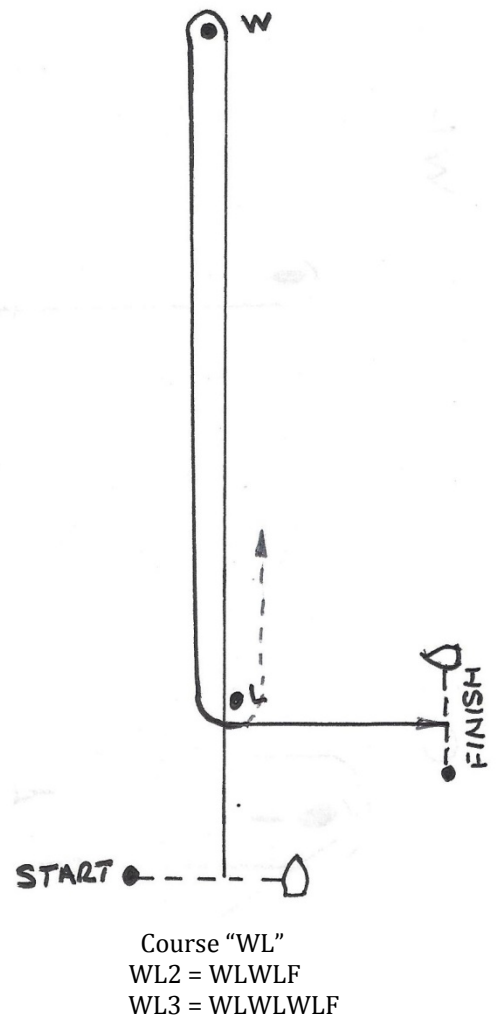
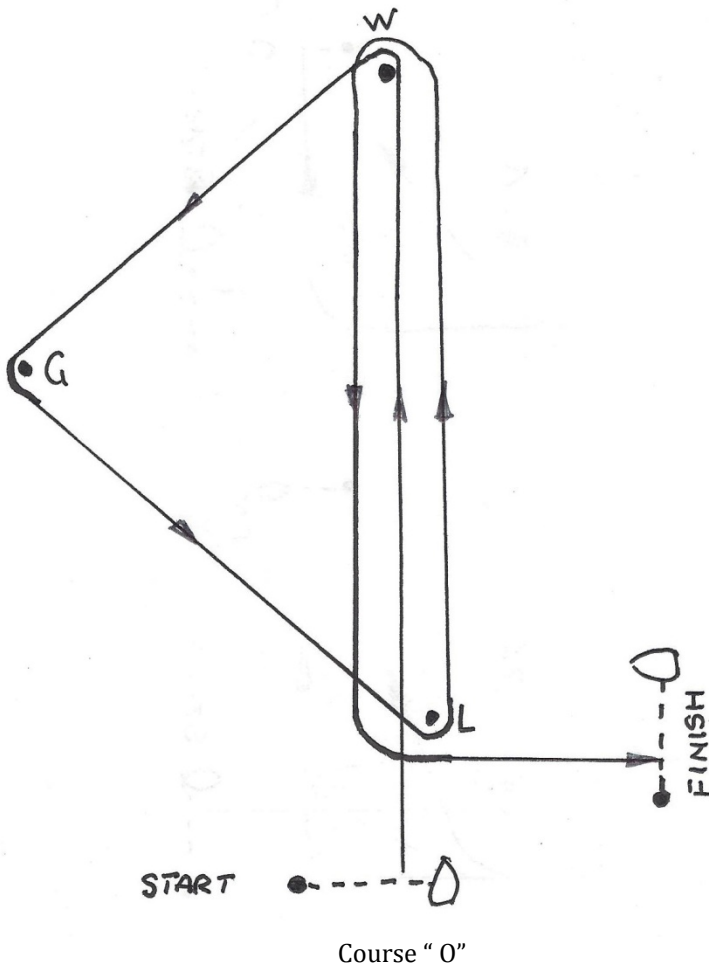
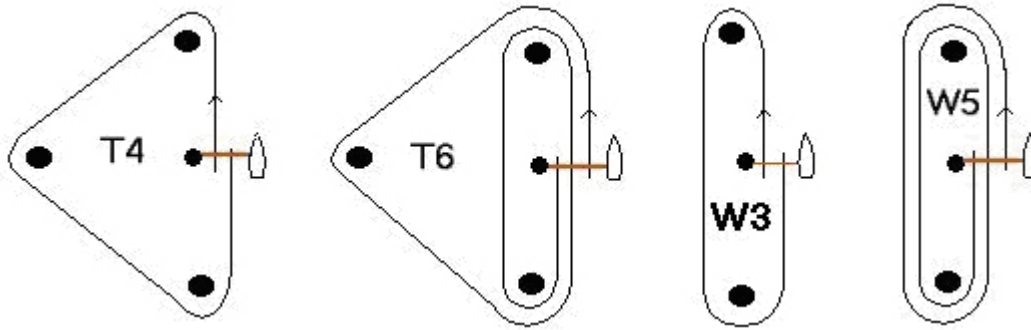

An Offset Mark may be used at the windward mark in which case the offset mark shall be rounded after the windward mark.

10 MARKS

10.1 The inflatable marks will be large (three foot or larger) orange or yellow triangles.

11 THE START

11.1 Before the first start each day, each boat shall sail past the Race Committee boat and identify themselves to R/C personnel by hailing the boat's name, sail number and class.

11.2 **THE STARTING LINE:** Shall be between an orange flag on a Race Committee boat & a nearby small orange inflated tetrahedron at the port end.

12 **THE FINISH**

- 12.1 The finish line shall be between orange flag on a Race Committee boat & a nearby mark of the course.
- 12.2 If the Race Committee intends to run additional races it shall display the second repeater as boats are finishing.

13 **TIME LIMIT**

- 13.1 The time limit for each Class race shall be one and one-half (1.5) hours. If the first boat in a class finishes within the time limit, other boats in that class will be allowed 30 more minutes beyond the first boat's finish..
- 13.2 After boats equal to 2/3 of the boats entered in a class have finished, the Race Committee may elect to score any remaining boats still racing in place.

14 **PROTESTS AND REQUESTS FOR REDRESS**

- 14.1 All protests must be presented to the Race Committee in writing within **one hour** after the Race Committee boat docks at Blackbeard Sailing Club.
- 14.2 All protests shall be heard on the same day, or as soon as practicable, at the Blackbeard Clubhouse.

15 **SCORING**

- 15.1 Appendix A – Scoring. *A4 Low Point System* shall be used to score this regatta.
- 15.2 If five races are sailed, there shall be one throw out.

16 **SAFETY REGULATIONS**

- 16.1 A boat retiring from the race, shall notify the Race Committee before leaving the race course area or, if that is not possible, immediately upon arriving ashore.
- 16.2 Any attempt by any contestant to exercise right of way, to cross in close proximity to, or to interfere with reasonable transit of the race area by a commercial vessel, shall be grounds for disqualification. Should such protest occur, the burden of proof is on the boat allegedly interfering with said vessel.
- 16.3 Swing keel boats will maintain their keels in the down position at all times.
- 16.4 Radio equipped boats shall monitor Channel 67 while racing.
- 16.5 If a Y flag (yellow and red diagonal stripes) is flown with one sound before the warning signal, then all competitors shall wear a PFD while racing (see RRS 40).
- 16.6 Single handed sailors shall wear PFD's while racing. This changes RRS 40.
- 16.7 Sailors on boats that are not self-rescuing shall wear life jackets while racing. This changes RRS 40.

17 **PRIZES**

- 17.1 Prizes shall be awarded based on the number of entries in each class.

18 **DISCLAIMER OF LIABILITY**

- 18.1 Competitors participate in the regatta entirely at their own risk. See rule 4, Decision to Race. The organizing authority will not accept any liability for material damage or personal injury or death sustained in conjunction with or prior to, during, or after the regatta